IP-12/IP-16
RADIO CONTROL SURFACE

TECHNICAL MANUAL

 *Wheatstone Corporation*

600 Industrial Drive, New Bern, North Carolina, USA 28562

IP-12 / IP-16 Radio Control Surface Technical Manual

©2014 Wheatstone Corporation

WHEATSTONE CORPORATION
600 Industrial Drive
New Bern, North Carolina 28562
tel 252-638-7000 / fax 252-637-1285

Attention!

Federal Communications Commission (FCC) Compliance Notice: Radio Frequency Notice

NOTE: This equipment has been tested and found to comply with the limits for a Class A digital device, pursuant to Part 15 of the FCC rules. These limits are designed to provide reasonable protection against harmful interference when the equipment is operated in a commercial environment. This equipment generates, uses, and can radiate radio frequency energy and, if not installed and used in accordance with the instruction manual, may cause harmful interference to radio communications. Operation of this equipment in a residential area is likely to cause harmful interference in which case the user will be required to correct the interference at his own expense.



This is a Class A product. In a domestic environment, this product may cause radio interference, in which case, the user may be required to take appropriate measures.

This equipment must be installed and wired properly in order to assure compliance with FCC regulations.

Caution! Any modifications not expressly approved in writing by Wheatstone could void the user's authority to operate this equipment.

Attention!

This Wheatstone IP-12/IP-16 system is factory configured as a stand alone system.

The IP-12/IP-16 control surface is configured with a default IP address of 192.168.87.201.

The WheatNet-IP 88cb Console BLADE3 is configured with a default IP address of 192.168.87.101.

If the default addresses will work for you, there is no need to do any network configuration of either the IP-12/IP-16 control surface or the Console BLADE3. However, if you intend to install the IP-12/IP-16 system as part of a larger WheatNet-IP system, you will need to change the default IP addresses of both the IP-12/IP-16 and the Console BLADE3. ***Careful consideration should be given when planning your IP Address scheme to ensure there are no IP address conflicts that could render the system inoperable.***



If you have additional questions or should you need assistance, please contact Wheatstone support. Support can be reached by calling 252-638-7000 or email at techsupport@wheatstone.com.

Adding The IP-12/IP-16 To The Peripheral Devices* Tab

In order to utilize all the features of the IP-16/IP-12 control surface the device must be added to the *System Peripheral Devices* tab in the Wheatstone WheatNet-IP Navigator program (aka the Navigator GUI). This sheet shows you the basics of that procedure. Refer to the *WheatNet-IP Audio Over IP Network Technical Manual* for additional details.

You will need to know the IP address of the device being added, so you will want to find that out before you start.

Launch the Navigator GUI and make sure that **System 0** is selected in the *System* pane. You will see something like this:



Now select the *Peripheral Devices* tab.

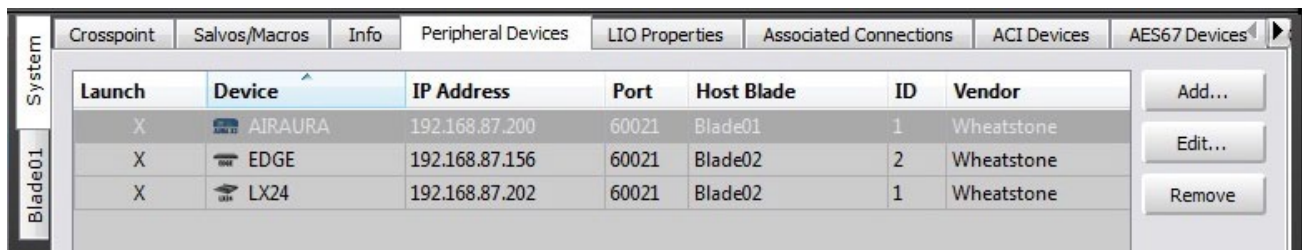

Click the *Add* button to bring up the *Add Peripheral Device* dialog:

Type in a convenient *Name* and insert the *IP Address* of the device being added. Leave the *TCP Port* at the default setting of **60021**. From the *Host BLADE* drop down select the *BLADE* that you want to associate the Peripheral device with. Click *Ok*.

This completes the process of adding the device to the *Peripheral Devices* tab. The added device should show up in the *System* pane under the *BLADE* you added it to. If it does not show up, or if it shows up but has a yellow question mark on it, then there is either a network issue that needs attention, or the device is not connected to the network at all, or one or more steps have been omitted or done incorrectly in the configuration process.

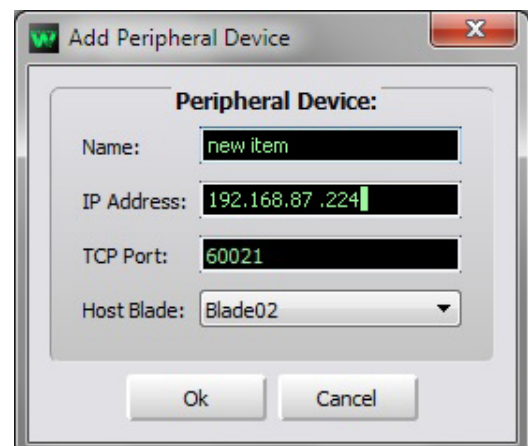

* In previous Navigator GUI versions this was the **System 3rd Party Devices** tab.

IP-12/IP-16 Technical Manual

Table of Contents

Chapter 1 - General Information

Introduction	1-2
Control Surface Placement	1-3
Power Supply	1-4
Failsafe Dual Redundant Supply	1-4
Connections	1-5
Energizing	1-5

Chapter 2 - Surface Configuration

Getting Started	2-2
Tabbed Navigation	2-3
System Info Pane	2-4
Engine Tab.....	2-6
Talent Access Tab.....	2-7
VDips Tab	2-8
Monitor Config Tab.....	2-11
Buttons Tab	2-12
Visibilities Tab	2-13
GUI Menu Summary	2-14
Changing The IP Address Of The IP-12/IP-16	2-15

Chapter 3 - IP-12/IP-16 Controls and Functions

Input Module (IN-12)	3-2
Input Sources	3-2
Assign Switches	3-3
The OL Bus.....	3-3
TB Switch	3-3
CUE Switch	3-3
Fader	3-3
Channel ON Switch	3-3
Channel OFF Switch	3-3

Control Room Module (CR-12)	3-4
CUE Level Control	3-4
SOFT KEY Buttons	3-4
ENCODER And TAKE Controls	3-5
Source Select Switches	3-5
Programming External Source Switches	3-5
CONTROL ROOM Level Control	3-6
METERS	3-6
VU Meter Pairs	3-6
METERS Select Button	3-6
Studio Control Module (SC-12)	3-7
Source Select Switches	3-7
Programming External Source Switches	3-7
STUDIO Level Control	3-7
TB (Talkback) Button	3-7
HEADPHONE Level Control	3-8
TIMER Buttons	3-8
EVENT Buttons	3-8

Chapter 4 - WheatNet-IP 88cb Console Blade 3

General Information	4-2
Installation Tips	4-2
Energizing	4-3
I/O Connections	4-4
Inputs	4-4
Outputs	4-6
Logic Ports	4-7
Console BLADE 3 88cb - Input/Output Pinout Drawing	4-8
Front Panel Metering	4-9
Front Panel Dual OLED's	4-9
Stand Alone System Setup	4-10
BLADE3 Setup Mode	4-10
BLADE3 SFront Panel Configuration	4-13
Front Panel Menu Diagram	4-15

Chapter 5 - Host CPU (HC-12)

Overview	5-2
Ethernet IP Addressing	5-2
Ethernet Interface Wiring	5-2
Hook-Ups	5-3
"CT20" RJ-45 - Main Ethernet Connector	5-3
Typical Straight-Through Cable	5-3

Chapter 6 - Schematic and Load Sheet Drawings

INSW-12 Input Module Switch Card

Schematic6-2

Load Sheet6-3

ONSW-12 Input Module On/Off Switch Card

Schematic6-4

Load Sheet6-5

CRSW-12 Control Room Module Switch Card

Schematic6-6

Load Sheet6-7

SCSW-12 Studio Control Module Switch Card

Schematic6-8

Load Sheet6-9

Appendix

Replacement Parts List.....A-2

General Information

Chapter Contents

Introduction	1-2
Control Surface Placement	1-3
Power Supply	1-4
Failsafe Dual Redundant Supply	1-4
Connections	1-5
Energizing	1-5



General Information

Introduction

The Wheatstone twelve- or sixteen-input IP-12/IP-16 control surface offers a great way for a small to medium radio operation to enter the world of networked audio. Tapping into the power of WheatNet-IP Intelligent Network technology through the use of the included WheatNet-IP 88cb audio Console BLADE3/mix engine, it's a perfect low-cost, small-footprint solution.

Each of the 12/16 input modules is equipped with an LED source name display and an A/B source selector whose sources can be set via a rotary encoder in the master section. Each input module has access to four program busses and has cue and talkback switches. A 100mm long-throw fader and lighted channel ON/OFF switches round out the module. The master section offers control room, studio, and headphone controls with source selection, and an onboard headphone jack and amplifier. Timer controls, a master talkback button, and a built-in cue speaker with volume control are provided. There are four event switches and six programmable buttons available for user functions. The meterbridge has three stereo pairs of bright 30-segment horizontal LED bargraph meters, as well as an on-board timer with controls located in the master section.

Control Surface Placement

The IP-12/IP-16 audio control surface is designed for countertop mounting. Although the rubber feet on the bottom keep the surface from being easily moved when simply placed on the counter, holes have been provided so that screws may be used to mount the surface securely to the countertop. Locate the IP-12/IP-16 on the counter, and remove the screws that hold the first and the last modules in place (two per module). Carefully remove these modules from the frame. Attach the mainframe to the counter top, using the holes provided in the bottom of the chassis and screws appropriate to the counter material, and reinstall the removed modules.

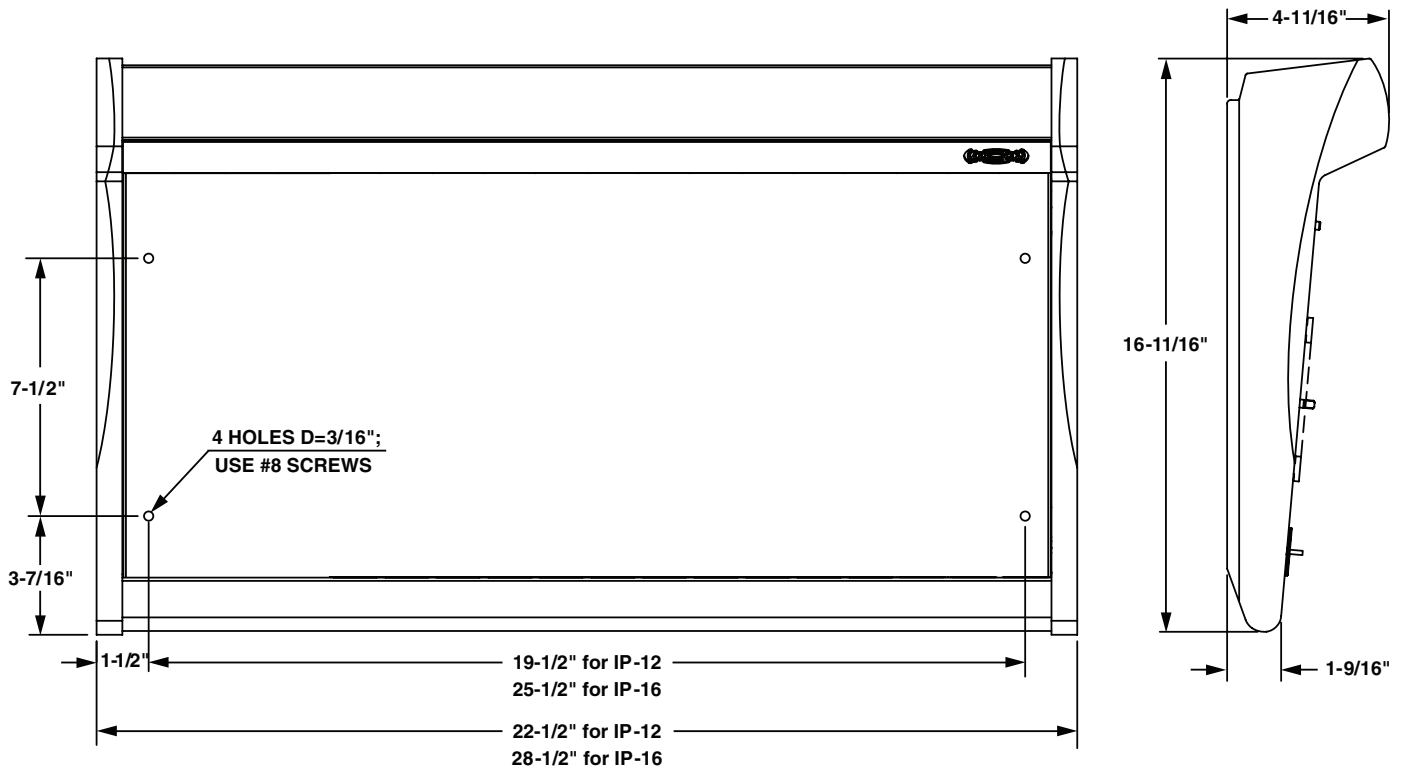
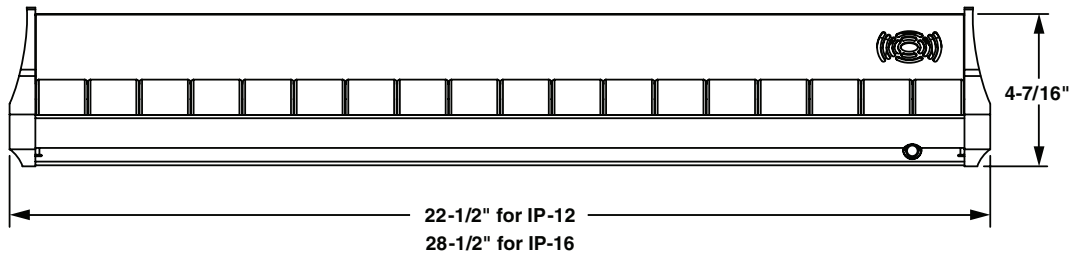

Power Supply

The IP-12/IP-16 control surface is powered by a Wheatstone Model HPS-516 power supply and connected using the factory supplied 10 foot long MIDI cable with 5-pin DIN plugs.



DC Power Output Pinout

	PIN #	OUTPUT
	1	COM
	2	COM
	3	+5VDC
	4	-15V
	5	+15V



The power supply is supplied with a 3-wire grounded AC cord that should be plugged into a “clean” AC power source, that is, an AC source that feeds only the control room audio gear. This source should be a separate feed from those powering lighting, air-conditioning, or any other non-audio machinery.

The power feed recommended in the text is often installed and referred to in studios as an “isolated AC ground” outlet. It is usually orange in color.

Note: The optional HPS-516 power supply rackmount installation kit is available.

Failsafe Dual Redundant Supply

Wheatstone failsafe power supply systems use two power supplies for each piece of powered equipment. Though either is capable of running a full load on its own, in failsafe operation both units run in tandem: if one fails, the other takes over, assuring uninterrupted operation.

Connections

The rear panel has two 5-pin DIN power supply connectors, mounted on the Host Controller card, for power supply connections.

The rear panel also has an RJ-45 connector that provides the control surface connection to a standard Ethernet network switch.

Unscrew the control surface's rear panel to access these connectors. Note that there is clearance at the bottom of the rear panel for cable passage.

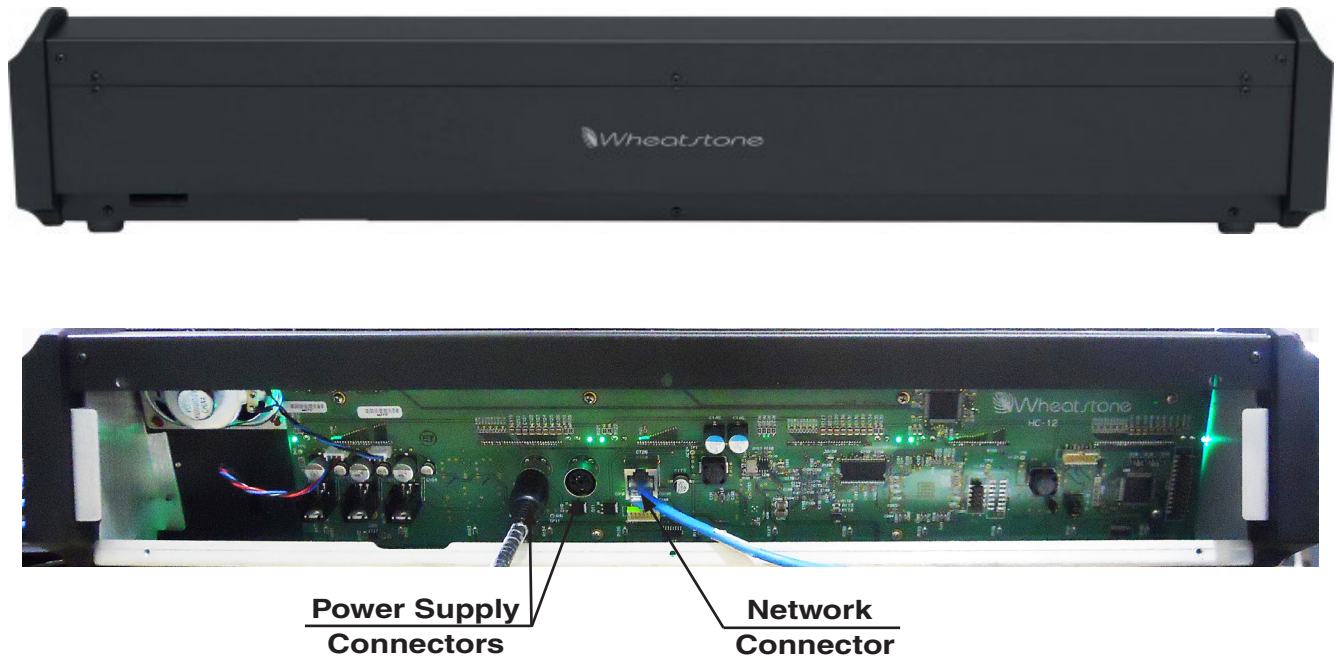

Energizing

Assuming the IP-12/IP-16 control surface is properly placed, and its power supply correctly connected to the control surface, you may now energize the power supply by plugging it into the AC mains. The control surface's switches and meterbridge displays will assume factory default settings.

Note: To de-energize the console, unplug the power supply adapter's AC cord from the AC mains. *Never de-energize the console by disconnecting the cable that connects the console and power supply adapter together.*

During the control surface booting up process the meterbridge 8-character LED displays will show the surface's software version. In the event that you need to consult the factory about the IP-12/IP-16 control surface, you may need to have this information.



Surface Configuration

Chapter Contents

Getting Started.....	2-2
Tabbed Navigation	2-3
System Info Pane	2-4
Engine Tab.....	2-6
Talent Access Tab.....	2-7
VDips Tab	2-8
Monitor Config Tab.....	2-11
Buttons Tab	2-12
Visibilities Tab	2-13
GUI Menu Summary	2-14
Changing The IP Address Of The IP-12/IP-16	2-15



Default IP Address - 192.168.87.201



Default IP Address - 192.168.87.101



Surface Configuration

Getting Started

The IP-12/IP-16 control surface connects via Ethernet to its audio engine, the Wheatstone WheatNet-IP 88cb audio Console BLADE3. Note that the Console BLADE3 must be connected to a Gigabit port on a switch. A powerful 1RU device containing the console's digital signal processing, input, output, and logic circuitry, the engine has no fans and may be located either next to the control surface or at a remote location.

The IP-12/IP-16 control surface comes with the *IP Series Console Setup Tool* Graphical User Interface (GUI) program, intended to be straightforward in setup connection between the control surface and the Console BLADE3. On a user-supplied computer connected through an Ethernet switch to the IP-12/IP-16 and the Console BLADE3, install the GUI by running the installer file *wheatnetip_ipconsole_setup_X_X_X.exe*, where "X_X_X" is replaced with the version number, such as "1_0_0". The installer creates a program with file name of *WheatNetIpConsoleGui.exe*. Double-click the icon for this file, or its shortcut, to run the GUI.

Tabbed Navigation

The IP-12/IP-16 GUI features a tabbed navigation architecture to easily access features with a minimum number of mouse clicks.

The IP-12/IP-16 GUI screen is vertically divided into two parts with a Function Pane on the left side and a System Info Pane on the right side. The Main Menu Tab buttons are located on the left side of the function display area. You may access any of the Main Menu Tabs by simply clicking on them.

At the bottom of the screen is a Devices Pane that displays a list of IP-12/IP-16 devices that the IP-12/IP-16 GUI has been configured to communicate with. Click *Add...* to add a device to the list, *Edit...* to change the name of an IP-12/IP-16 or give the GUI a different IP address to talk to it on, or *Remove* to delete the device currently highlighted in the list. To the right of these buttons is the *Online* checkbox, which is used to toggle the GUI connection to the highlighted device between online (checked) and offline (not checked).

The Function Pane and System Info Pane contents change according to the tab selected in each area. Both of these Panes are relocatable within the GUI window by clicking on the Pane's handle (the rows of the double dots with the Pane name in between) and dragging the Pane to the new location. You can even drag one or both of these Panes outside of the GUI window, a handy feature if you have two monitors. To bring a Pane back into the GUI, double-click its title bar.

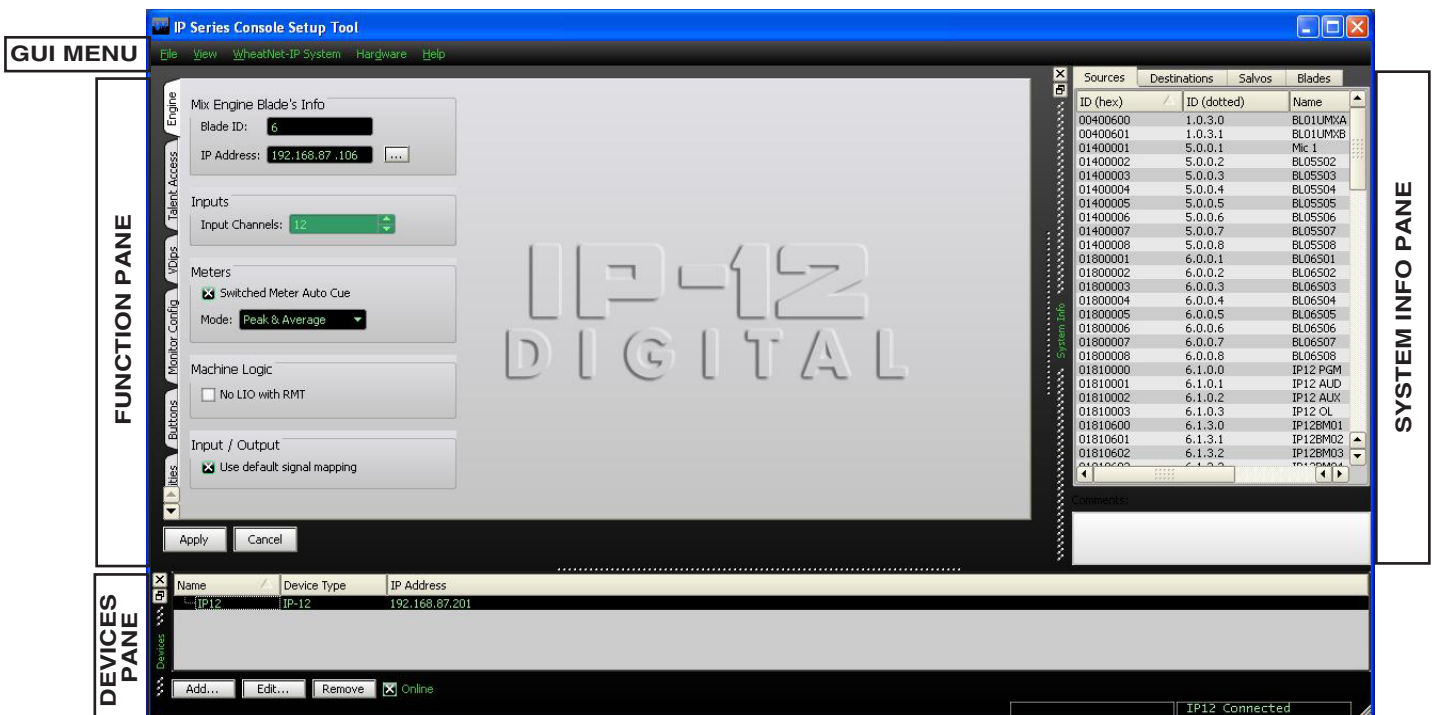

System Info Tab

When you first start the IP-12/IP-16 GUI there will be no information showing in the System Info Pane. Assuming that you are connected to a working system, you can get this pane to fill by selecting *WheatNet-IP System>System Scan...* from the GUI menu. This will display the *WheatNet-IP System Scan* screen:

Start by specifying the *Host Blade IP Address*. This can be the IP address of any physical BLADE in the system. Next, click *Start Scan*. When the scan is complete you will see a screen like this (the exact text is system-dependent):

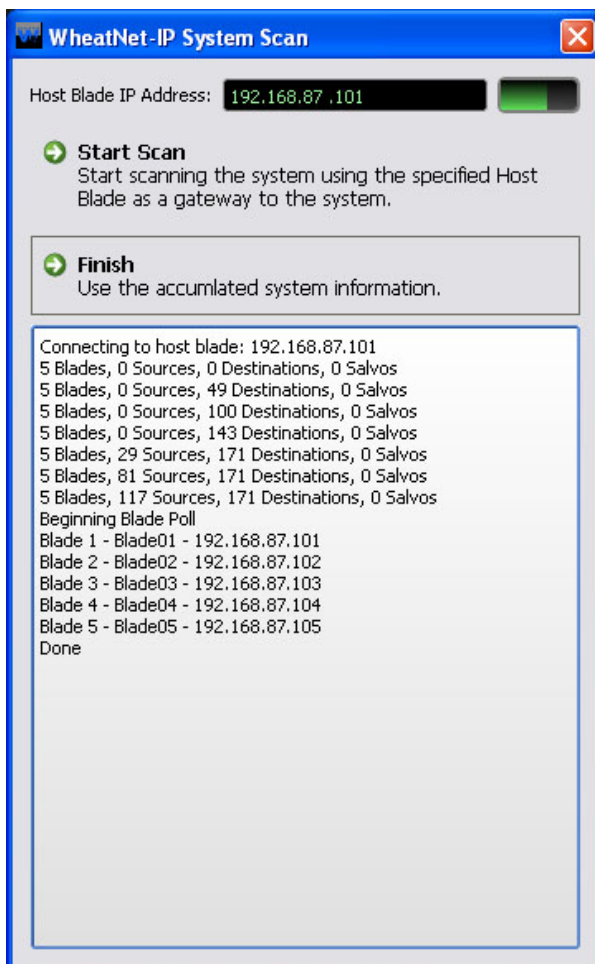
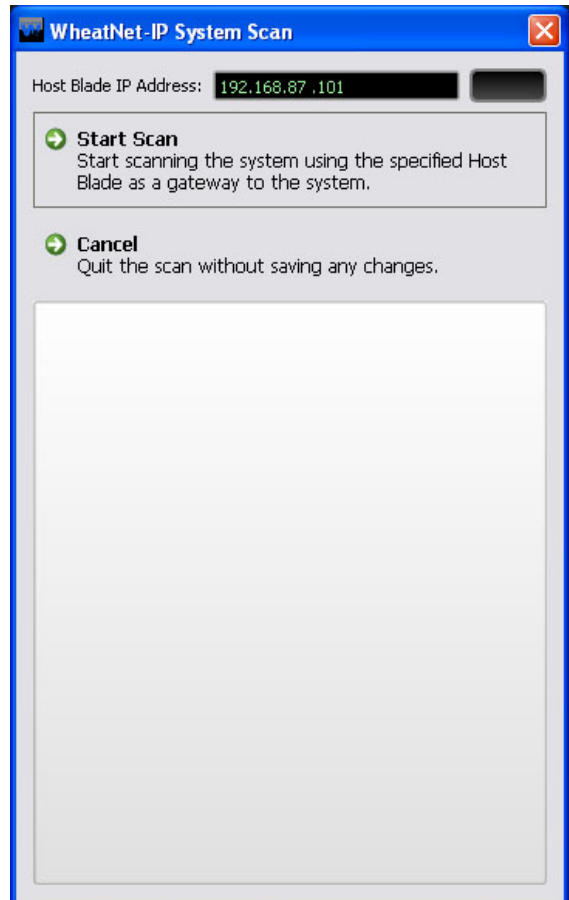

Click *Finish*. You will be asked if you want to save the System Info. If you click *Yes* you will be prompted for the location and name of the saved file, and also given a chance to write a brief description of this saved data set, but for now just click *No*.

You will notice that the System Info Pane now has content. Here is an example of what you might see on the *Sources* tab (remember, your signal names and other information will almost surely be different than the data shown here):

ID (hex)	ID (dotted)	Name	Location
00800012	2.0.0.18	SS N2C5p	SN RACK1
00800600	2.0.3.0	U-PR1H/P	SN RACK1
00800601	2.0.3.1	BLO2UMXB	SN RACK1
00800602	2.0.3.2	BLO2UMYA	SN RACK1
00800603	2.0.3.3	BLO2UMYB	SN RACK1
00C00001	3.0.0.1	HOST A	SN MCR1
00C00002	3.0.0.2	HOST B	SN MCR1
00C00003	3.0.0.3	HOST C	SN MCR1
00C00004	3.0.0.4	HOST D	SN MCR1
00C00005	3.0.0.5	HOST E	SN MCR1
00C00006	3.0.0.6	OP MIC	SN MCR1
00C00007	3.0.0.7	PROD1MIC	SN MCR1
00C00008	3.0.0.8	TV 1	SN MCR1
00C00009	3.0.0.9	TV 2	SN MCR1
00C0000A	3.0.0.10	APC88RLY	SN MCR1
00C00600	3.0.3.0	U-HOST A	SN MCR1
00C00601	3.0.3.1	U-HOST B	SN MCR1
00C00602	3.0.3.2	U-HOST C	SN MCR1
00C00603	3.0.3.3	U-HOST D	SN MCR1

Comments:
signal set description

As we discuss the GUI there will be times when we need to access signal names. If you have not scanned the system, or loaded a saved data set, you will not be able to see or choose individual signals.

Engine Tab

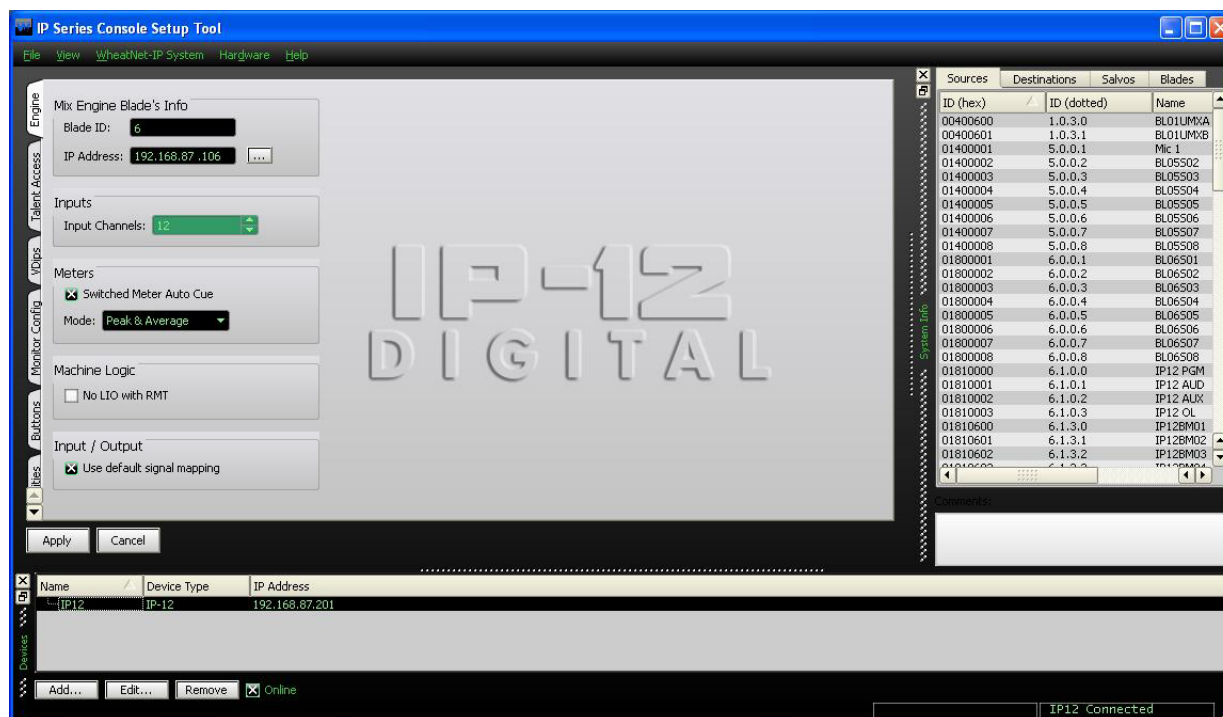

Mix Engine Blade's Info – In this section you will set the Mix Engine *Blade ID* and the *IP Address* of the the Engine to which the surface will connect.

Inputs – Not Used.

Meters – The switched meter on the surface's meterbridge displays the signal level of a user selected source or the Cue signal level when an input fader's CUE switch is activated. To activate the Auto Cue function check the *Switched Meter Auto Cue* box. Use the *Mode* dropdown box to choose from *Peak & Average*, *Peak Only*, or *Average Only*.

Machine Logic – The purpose of this option is to allow the privileged operator to determine the conditions under which START and STOP signals are sent in response to a command to turn a channel ON or OFF. Channel ON and OFF commands can come from two different sources:

- **Surface** – A channel can be turned ON or OFF by a surface action, such as pressing the ON or OFF switch, or moving a fader if EFS has been enabled
- **Remote (RMT)** – A channel can be turned ON or OFF by sending it a command from a system Logic I/O card via the RemOn and RemOff functions.

When the **No LIO with RMT** check box is checked, LIO signals are globally blocked for all input faders if the channel ON and OFF commands are initiated from the system Logic I/O card.

Input/Output – In most cases, you will want the *Use default signal mapping* check box to be checked, to insure that signals are properly mapped. This insures that the surface signals appear at the designated connectors on the Console BLADE3. If you want to re-arrange or re-purpose the signals, leave this check box unchecked.

Talent Access Tab

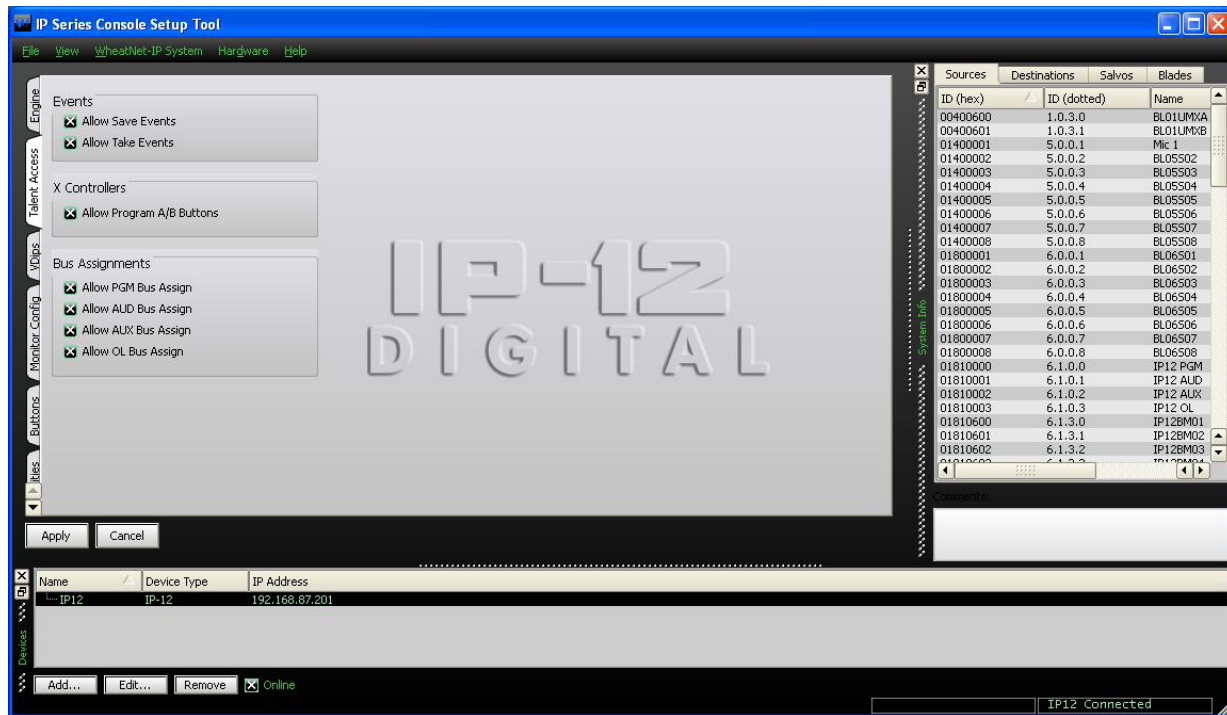

It may be desirable to limit some of the operations that can be performed by talent using the IP-12/IP-16.

Events – Operation of the four EVENT buttons on the SC-12 Studio Control Module can be limited as follows:

- If **Allow Save Events** is not checked, the operator will not be able to program the EVENT buttons to save Events.
- If **Allow Take Events** is not checked, the operator will not be able to use the EVENT buttons to take Events.

X Controllers – Selection of fader sources by using the A and B INPUT buttons on the IN-12 Input Module can be limited as follows:

- If **Allow Program A/B Buttons** is not checked, the operator will not be able to use the A and B INPUT buttons to change fader sources.

Bus Assignments – Use of the ASSIGN buttons (PGM, AUD, AUX, and OL) to determine the bus or buses that the fader will feed can be limited as follows:

- If **Allow PGM Bus Assign** is not checked, the operator will not be able to use the PGM ASSIGN button to change the fader's feed status to the PGM bus.
- If **Allow AUD Bus Assign** is not checked, the operator will not be able to use the AUD ASSIGN button to change the fader's feed status to the AUD bus.
- If **Allow AUX Bus Assign** is not checked, the operator will not be able to use the AUX ASSIGN button to change the fader's feed status to the AUX bus.
- If **Allow OL Bus Assign** is not checked, the operator will not be able to use the OL ASSIGN button to change the fader's feed status to the OL bus.

VDips Tab

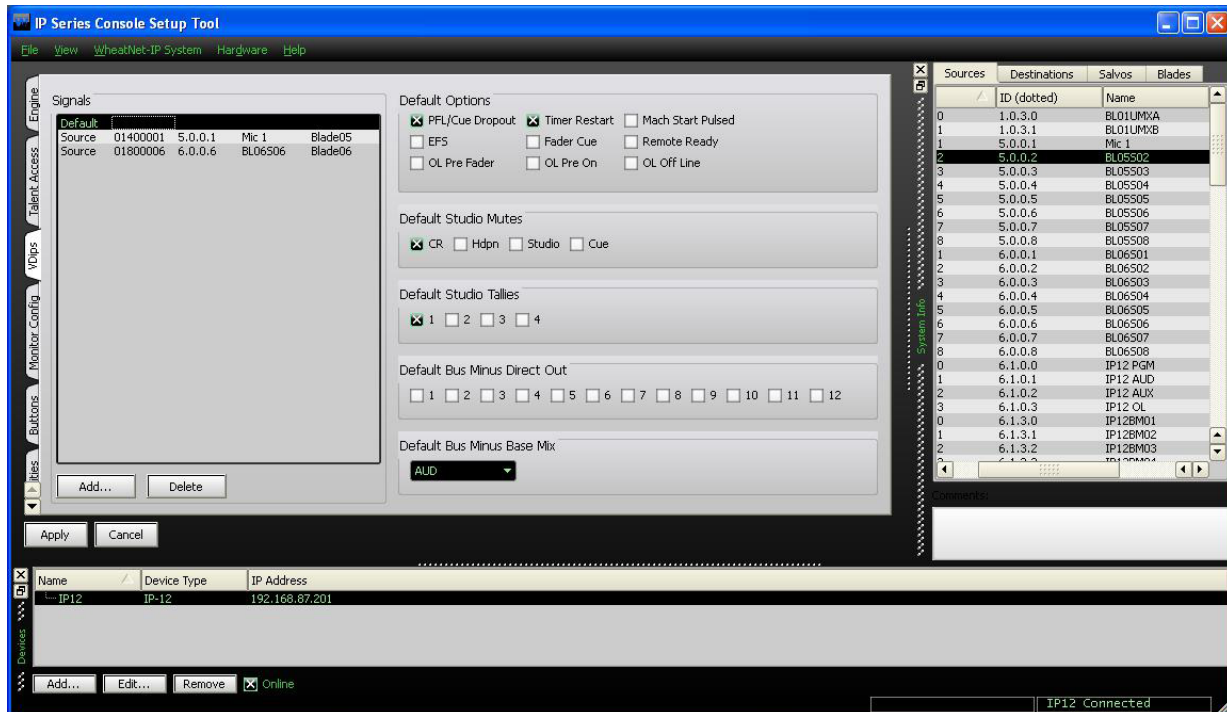

Many surface functions, such as Mute, Tally, and Machine Start Pulsed, are programmed from the VDips tab. VDip settings are attributes of the Source signal and will follow the signal onto different faders of the surface, or even other surfaces.

When the IP-12/IP-16 GUI is first started, the VDips tab *Signals* list contains only one item, *Default*. If you select *Default* you will be editing the VDip settings of all sources in the system, except those you have specifically overridden.

If you want to edit the VDip settings of a specific signal to be different than the default settings you first need to add the signal to the *Signals* list. Click the *Add...* button to bring up the *Add Signal* dialog.

Click the button with the three dots (ellipsis) to the right of the *Source Signal* field to bring up the *Source Picker* dialog.

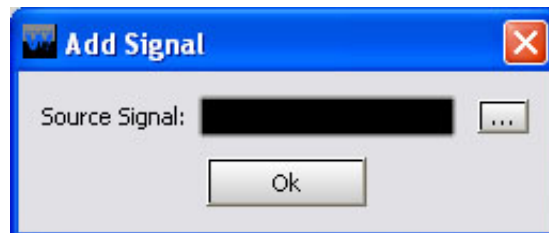

Find the desired source in the *Source Picker* and double-click on it. This returns to the *Add Signal* dialog with the selected signal's ID in dotted notation in the *Source Signal* field:

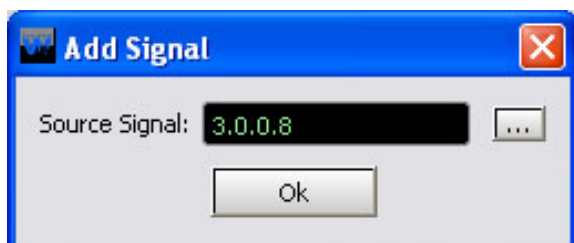

Click *Ok* and the selected signal now appears in the *Signals* list on the VDips tab. You can now select this signal in the *Signals* list and edit its VDip settings.

Once you have edited VDip settings you must click *Apply* for those changes to be used. If you've done some VDip editing and decided you don't want to make

that particular change after all you can click *Cancel*, which will cancel any changes you made since entering the VDips tab, or since you last clicked *Apply*.

If you want to set VDip the same on several sources, begin by setting up one signal. Then highlight that source in the *Signals* list and right-click on the area. Select *Copy* from pop-up. Now highlight another signal you want to have the same VDip settings, then right-click and select *Paste*. This copies the VDip settings from the first signal to the second one.

Please note that all VDip settings apply to the programmed signal regardless of which fader the signal appears on.

PFL/Cue Dropout – When a channel's CUE button is pressed it will assign the channel's signal to the CUE bus. When *PFL/Cue Dropout* is checked it causes the channel's CUE function to be de-activated whenever the channel ON switch is pressed.

EFS – This function causes the channel to turn OFF when the fader is fully down or turn ON when the fader is brought up from the fully down position. The ON and OFF switches can still control the channel.

OL Pre Fader – When checked, causes the signal, when assigned to the surface's OL output, to be tapped before the fader.

Timer Restart – The surface's digital timer can be programmed to automatically reset to zero and begin counting up when the channel's ON button is pressed. To enable this function the AUTO button in the timer section of the SC-12 Studio Control Module has to be activated.

Fader Cue – Assigns the signal to the Cue bus when the fader is moved all the way down. The CUE button can still be used to change the CUE status.

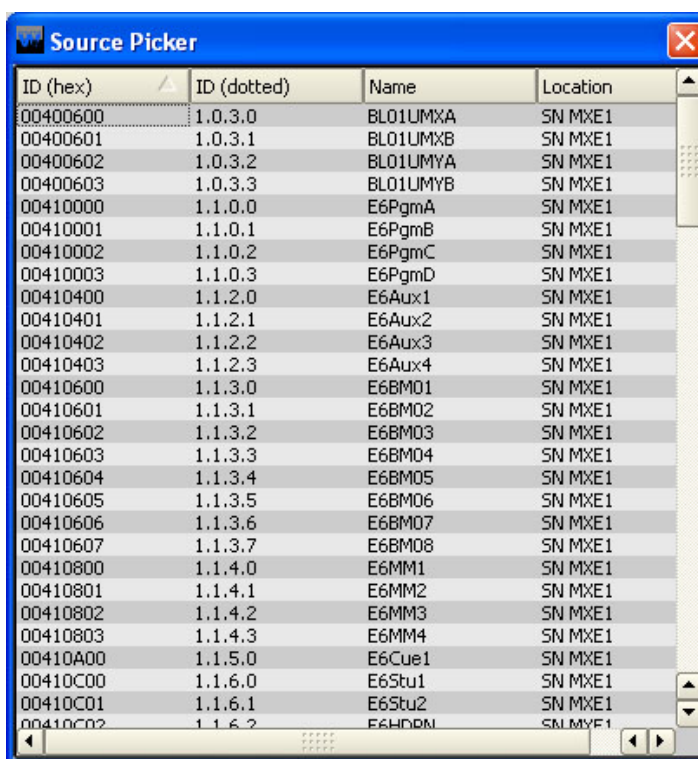

OL Pre On – When checked, causes the signal, when assigned to the surface’s OL output, to be tapped before the channel ON switch.

Mach Start Pulsed – If this box is not checked, a Machine Start command will give a steady closure, similar to an On Tally. If your external machine needs to see a momentary pulse instead, check this box.

Remote Ready – The channel’s OFF switch normally has its LED indicator controlled by the switch itself. This is the factory default setting. When *Remote Ready* is checked, the channel’s OFF switch LED can be controlled by an external source machine. This requires additional configuration in the optional Navigator GUI to fully implement the feature.

OL Off Line – This function determines what will be heard at the fader’s Bus Minus output when the fader is off. If the box is not checked, when the fader is off the same bus will feed the bus minus that feeds it when the fader is on, as determined by the *Bus Minus Base Mix* selection below. But if the OL Off Line box is checked, when the fader is off the Bus Minus output will be fed from the OL bus instead.

Studio Mutes – Input channels can be programmed to mute the various monitors when the channel is ON. There are four *Studio Mutes* check boxes, one for each monitor section plus one for CUE. The checked boxes show which monitors are muted.

Studio Tallies – Turning the channel ON can activate a remote tally indicator. There are four tally control lines. The checked boxes show which tallies are activated. This requires additional configuration in the optional Navigator GUI to fully implement the feature.

Bus Minus Direct Out – For each fader, determines if the Bus Minus output is a mix-minus of the selected Bus Minus Source (unchecked) or is a Direct Output of the selected input source (checked). On faders where the *Bus Minus Direct Out* box is checked, the OL Off Line box (above) will have no effect.

Bus Minus Base Mix – This function determines which bus the Bus Minus output is a mix-minus of. Any of the four PGM, AUD, AUX, or OL busses can be selected as the Bus Minus Source. If, for example, PGM is selected, then the Bus Minus output will consist of the audio on the PGM Bus, minus the signal assigned to the fader. This is true when the fader is turned on. It also true when the fader is turned off, **unless** the *OL Off Line* box is checked (above). This setting will have no effect on any fader where the *Bus Minus Direct Out* box is checked (above).

Monitor Config Tab

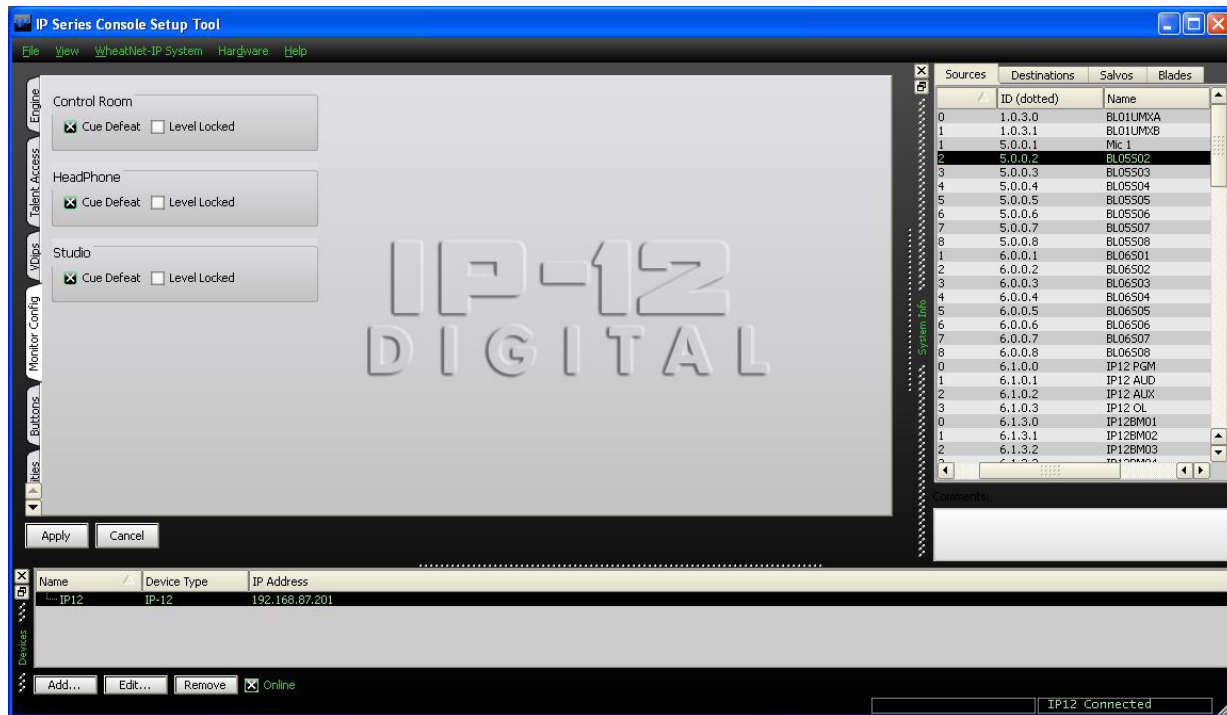

The Control Room, Headphone, and Studio monitor outputs are normally interrupted with cue audio whenever a fader is switched into cue. However, if the *Cue Defeat* box is checked for a given monitor, then cue will no longer interrupt that monitor output.

The output levels of the three monitors normally follow their respective level controls on the CR-12 Control Room Module and the SC-12 Studio Control Module. But it is possible to lock the level of each of the monitors.

Using the studio monitor as an example, adjust the STUDIO level control on the SC-12 to the desired level, then check the *Level Locked* box in the *Studio* section of the Monitor Config tab. The monitor output will remain at the fixed level regardless of any changes in the STUDIO level control position. If at a later time you decide to unlock the level, the level will still be unchanged until the next time the STUDIO knob is moved, at which point it will follow the knob once again.

After making changes you must click *Apply* for the changes to take effect. If you've made a change and decided you don't want to make that particular change after all you can click *Cancel*, which will cancel any changes you made since entering the Monitor Config tab, or since you last clicked *Apply*.

Buttons Tab

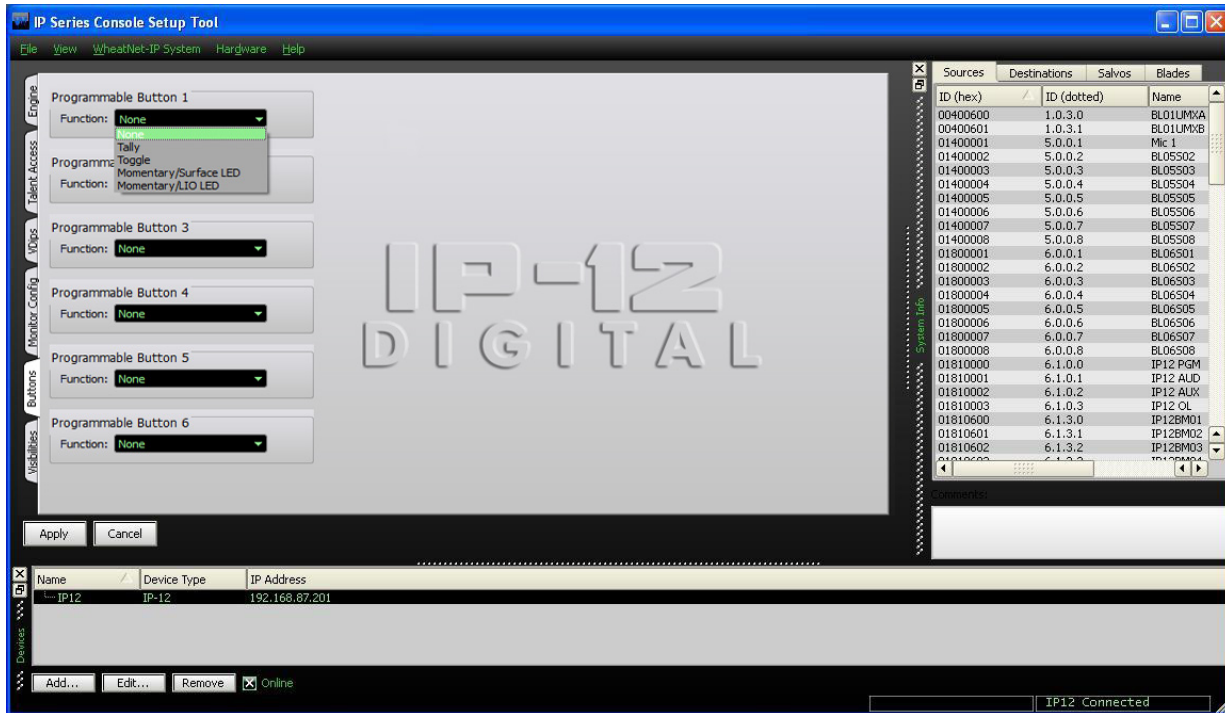

The CR-12 Control Room Module has, among its controls, six SOFT KEY buttons with indicating LEDs, labeled P1, P2, P3, P4, P5, and P6. These buttons are also known as Programmable Buttons, and are designed to perform user-programmable functions.

The *Buttons* tab is used to set up each button at a basic level of functionality by using the *Function* drop-down box on the *Buttons* tab for the particular button 1 – 6 being used. The choices are:

- **None** – In this mode button presses are ignored and the button does not light
- **Tally** – In this mode button presses are ignored – the button illumination is controlled by a logic signal programmed to do so
- **Toggle** – In this mode the button acts like a toggle, with one press turning it on and the next press turning it off – the button is illuminated by the surface when in the on state and is not illuminated in the off state
- **Momentary/Surface LED** – In this mode the button has a momentary action, on while pressed and off when released – the button's illumination is controlled by the surface, being lit while the button is pressed
- **Momentary/LIO LED** – In this mode the button has a momentary action, on while pressed and off when released – the button's illumination is controlled by a logic signal programmed to do so

It's important to note that, although basic functionality is set here, in all cases except **None** there will be additional configuration, needed to complete the desired functionality, that must be done in the optional Navigator software. Refer to the *WheatNet-IP Audio Over IP Network* manual for details.

Visibilities Tab

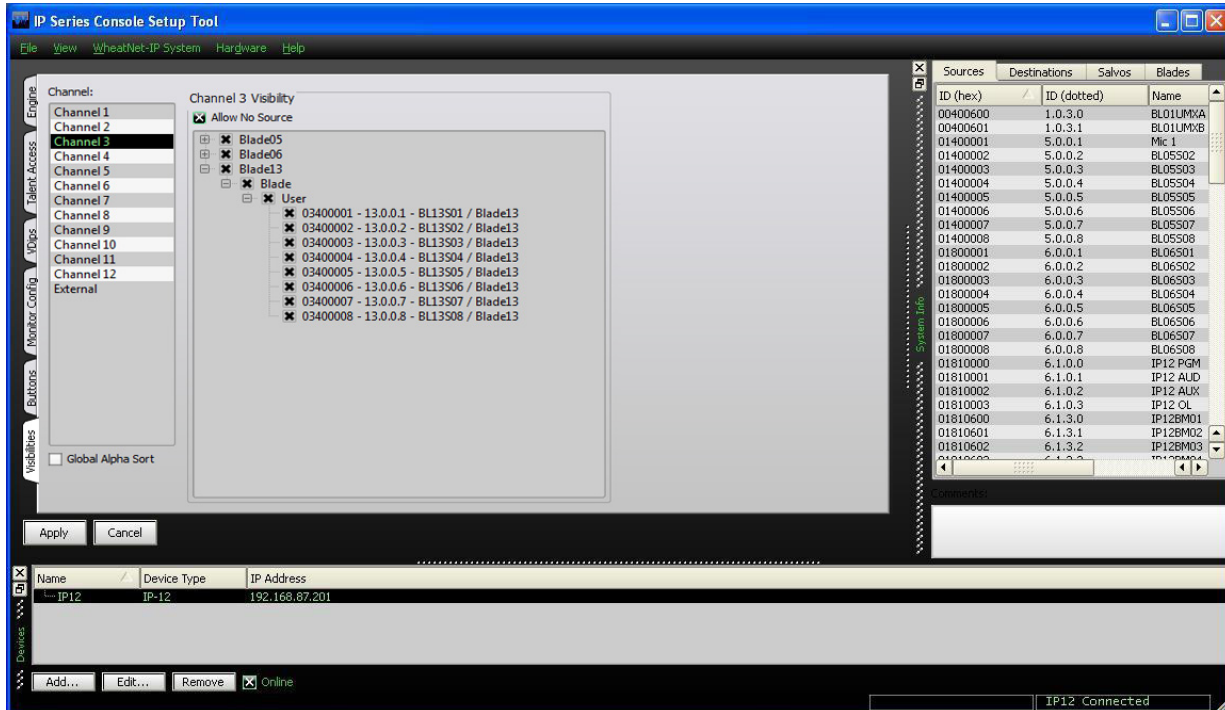

Visibilities – Use the Visibility Option setting to limit the sources the user sees when dialing up a source on the IP-12/IP-16. This feature is helpful, especially in large systems with lots of signals.

Scroll up and down the Channel list, check or uncheck signals as desired for that channel, and click the *Apply* button to save the visibility options. If you have made changes and then decided you don't want to put the changes into effect, click *Cancel*. This will cancel any changes you made since entering the screen or since clicking *Apply*, whichever happened most recently.

Check the *Global Alpha Sort* box to sort the list of channels in alphanumeric order when selecting sources on the IP-12/IP-16.

Check *Allow No Source* if you want NOSOURCE to be allowed for that channel. If NOSOURCE is not allowed then the channel must always have a source selected.

Right-clicking in the Channel area of the Visibilities tab pops up a menu with some useful shortcuts on it:

- **Copy** – Choose this item to copy the visibility settings of the currently selected channel.
- **Paste** – Choose this item to paste visibility settings that have been copied from one channel to the currently selected channel.
- **Paste All** – Choose this item to paste visibilities that have been copied from one channel to all channels.
- **All** – Choose this item to select all signals in the system to be visible to the currently selected channel. This also puts a check in the *Allow No Source* check box.
- **None** – Choose this item to deselect all signals for the currently selected channel. This also removes the check, if present, in the *Allow No Source* check box.

GUI Menu Summary

The various menus in the IP-12/IP-16 GUI are outlined below.

File – The *File* menu contains items for setting a password and for exiting the program:

- **Set Password...** – Used to set a password that will need to be entered to operate the IP-12 GUI – when first installed the GUI requires no password – to set a password you must enter the current password and then enter the new password twice (the second to confirm the password)
- **Exit** – Used to exit the IP-12/IP-16 GUI

View – The *View* menu is used to show or hide certain sections of the IP-12/IP-16 GUI or to change the GUI appearance:

- **Devices** – Used to show or hide the Devices Pane (see page 2-3)
- **System Info** – Used to show or hide the System Info Pane (see page 2-3)
- **Stylized** – Used to toggle the IP-12/IP-16 GUI between a modern appearance and a more traditional one

WheatNet-IP System – The *WheatNet-IP System* menu is used to manage signal sets within the IP-12/IP-16 GUI:

- **File Open...** – Used to open a saved signal set
- **File Save...** – Used to save the current signal set
- **System Scan...** – Used to scan the system to which the IP-12/IP-16 GUI is connected to get a list of all signals currently available in the system (see page 2-4) – this set can then be saved using *File Save...* and then later recalled using *File Open...* even if the IP-12/IP-16 is not connected to the system at that time

Hardware – The *Hardware* menu is used to set up devices in respect to connecting to them and managing their configuration and software:

- **Add New Device...** – Used to set up a new IP-12/IP-16 for the GUI to communicate with (see page 2-3) – brings up a dialog box to set a name, device type, and IP address
- **Edit...** – Used to change the setup parameters for the highlighted IP-12/IP-16 using a similar dialog box
- **Remove** – Used to delete the highlighted IP-12/IP-16 from the list after confirming the delete
- **Assign IP Address...** – Used to change the actual IP address of an IP-12/IP-16 – see details on the following page
- **Version...** – Used to check the current version of software of the currently connected IP-12/IP-16 – this information may be needed in the event that Wheatstone Technical Support needs to be contacted about the IP-12/IP-16
- **Update...** – Used to change the software version of the currently connected IP-12/IP-16
- **Reboot...** – Used to reboot the currently connected IP-12/IP-16 – this is used primarily after doing a software update

Help – The *Help* menu gives additional information about the IP-12/IP-16 GUI:

- **About...** – Used to show the version of the IP-12/IP-16 GUI.

Changing The IP Address Of The IP-12/IP-16

The IP address of an IP-12 can be changed from the GUI when the GUI is connected to the IP-12/IP-16 that needs changing. Select *Hardware>Assign IP Address...* from the IP-12/IP-16 GUI to see the *IP Assignment* dialog box:

Enter the *MAC Address*, which you will find on a label on the IP-12/IP-16. Enter a *Name* for the IP-12/IP-16 and specify the *IP Address* for the IP-12/IP-16. If needed, change the default *Subnet* and *Gateway* settings (see your friendly IP person to find out what you should use). Please note, when entering any of the network parameters (everything you are changing on this screen except the *Name*) it is best to highlight the complete default entry, delete it, then type in the complete new entry. In the *IP Address*, *Subnet*, and *Gateway* fields use the period (aka dot) to move from one octet to the next to avoid having leading spaces.

Once all the data is properly entered in the dialog, click *START* to begin the process. You will be prompted to reboot the IP-12/IP-16.

Click *OK* to dismiss the reboot prompt (but make sure the *IP Assignment* dialog is still showing).

Reboot the IP-12/IP-16 by cycling power to it (you will not be able to use *Hardware>Reboot...* to do this). Watch the *Requests* entry near the bottom of the *IP Assignment* dialog. You should see this number increment to something other than **0**. Once you see the *Requests* number change, you can click *STOP*, then click the red **X** in the upper right corner of the *IP Assignment* dialog. The IP-12/IP-16 now has the new network parameters you have assigned to it.

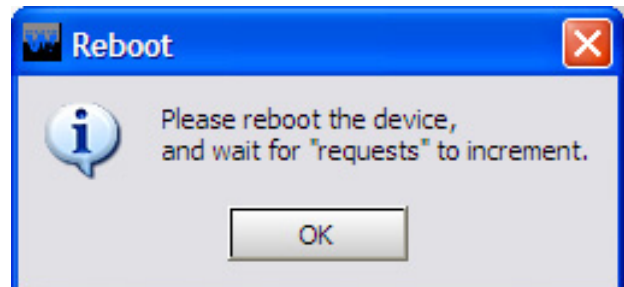

IP-12/IP-16

Controls and Functions

Chapter Contents

Input Module (IN-12)	3-2
Input Sources	3-2
Assign Switches	3-3
The OL Bus.....	3-3
TB Switch	3-3
CUE Switch	3-3
Fader	3-3
Channel ON Switch	3-3
Channel OFF Switch	3-3
Control Room Module (CR-12)	3-4
CUE Level Control	3-4
SOFT KEY Buttons.....	3-4
ENCODER And TAKE Controls.....	3-5
Source Select Switches	3-5
Programming External Source Switches.....	3-5
CONTROL ROOM Level Control	3-6
METERS	3-6
VU Meter Pairs	3-6
METERS Select Button	3-6
Studio Control Module (SC-12)	3-7
Source Select Switches	3-7
Programming External Source Switches.....	3-7
STUDIO Level Control	3-7
TB (Talkback) Button	3-7
HEADPHONE Level Control	3-8
TIMER Buttons	3-8
EVENT Buttons.....	3-8

IP-12/IP-16 Controls and Functions

Input Module (IN-12)

Input Sources

The A and B INPUT buttons at the top of each module determine what input source will feed the module. The buttons can be programmed to allow quick selection of two different sources for each module. If the source programmed for button A is the current source for the channel, then button A will be lit. Similarly, button B lights if its programmed source is the current source for the channel. The 8-character alphanumeric display above the channel on the meterbridge shows the name of the current source for that channel. If there is no current source for a channel, neither A or B button will be lit, and the display will read **NoSource**.



To select a new source, press and hold the desired button, A or B, until it begins to flash. This acts to arm the button to take its source. While the button is flashing, the display shows the programmed source for the selected button, or NoSource if the button is not programmed. Once the button is flashing, release it, and then press it again. This will cause the current source for that channel to be replaced by the one programmed for the selected button. If you don't press the button the second time, the button will stop flashing after a short timeout and the source will not be changed.

A similar process is used to program a source for a button. Press and hold the desired button until it flashes, then rotate the ENCODER on the CR-12 module until the desired source appears in the channel's display, then press the TAKE button (which is also flashing) below the ENCODER to finish programming the button. Please note that this process does not replace the current source for the channel, but only programs the selected button. If you then want to change to the source you just programmed you must press and hold the button again until it flashes, then press it one more time to take the new source to the channel.

There may be times when you don't want to change the programming for either A or B but want to select a third source for the channel. You can do this by pressing and holding both A and B together until both are flashing, then dialing up the desired source on the ENCODER and pressing TAKE. This will immediately take the third source to that channel and the A and B buttons will go off (to indicate the current source is not programmed for either A or B). This source is not remembered as a third source for the channel. Do a new source selection (A or B) and the next time you want a third source you will need to repeat the above process.

Depending on how the IP-12/IP-16 is configured, you may be able to select any source in the system or you may have a limited choice of sources for one or more of the channels.



Assign Switches

Output switches assign the selected source signal to any combination of the surface's four stereo outputs – PGM (program), AUD (audition), AUX (auxiliary), and OL (off line). The button will be lit when the source is assigned to its respective bus. To remove a source from the bus, press the button again; the light will go off to indicate that the source is no longer assigned to that bus.

User access privileges may be configured to limit Bus Assignment on the Talent Access tab of the *IP Series Console Setup Tool* GUI.

The OL Bus

The OL Bus has a special function in relation to a channel's Bus Minus output. Each signal that can be assigned to a channel will specify which bus (PGM, AUD, AUX, or OL) provides the base Bus Minus mix (that is, which bus the Bus Minus output is a mix-minus **of**) when that channel is on. When the channel is off, however, the base Bus Minus mix may be the same as when the channel is on, or may be configured to utilize the OL bus instead. This allows the Bus Minus output to have different content when the channel is off than it does when the channel is on.

Both the base Bus Minus mix and the use of the OL bus as base when the channel is off are configured in the *VDip* settings (see the section *VDips Tab* in chapter 2).

TB Switch

The TB switch routes the TB audio, typically the operator's microphone, to the BUS MINUS output for that channel, allowing the operator to talkback to the talent hearing that BUS MINUS signal. To set the TB audio source, make a crosspoint between the desired source and the destination signal IP12TkBk.

CUE Switch

The CUE switch assigns the selected source to the CUE bus, letting the control surface operator monitor the channel's pre-fader signal.

Fader

Channel output level is set by a 100mm, professional, conductive plastic linear fader.

Channel ON Switch

The channel ON switch turns the channel signal ON and fires any channel ON (START) logic to the fader's source signal. The switch LED lights to indicate the channel is ON.

Channel OFF Switch

The channel OFF switch turns the channel signal OFF and fires any channel OFF (STOP) logic to the fader's source signal. The switch LED lights to indicate the channel is OFF.



Control Room Module (CR-12)

This is the console operator's monitor that allows the operator to listen to the console's four stereo outputs and two external stereo line level inputs. This module includes the cue level control, switched meter selection, programmable buttons (soft keys), the source select encoder and take button, and source select and level control for the control room and headphone outputs.

In a typical radio application the console is located in the Control Room. Speakers in the Control Room allow the console operator to listen to the console bus outputs to be assured that the console is performing as desired. These speakers are fed by a stereo signal from the console's Control Room output. In addition to the Control Room output, the operator may also desire to listen to specific isolated faders via the cue system and the console's internal cue speaker. Thus, the control room monitor consists of the above mentioned level controls, along with four source select (PGM, AUD, AUX and OL) buttons, as well as two programmable X1 and X2 buttons. In some instances the console operator may also be performing talent whose voice will be heard over the radio. The operator's microphone may thus provide a part of the signal that is going out over the air. If that signal is the one being monitored with the Control Room speakers, there is the potential for feedback. The amplified signal from the Control Room speakers is picked up by the microphone and amplified to a new, higher, level, which then is once again picked up by the microphone. The signal quickly rises to an ear-splitting screech. To prevent this, the operator's microphone is normally set to MUTE the Control Room output to prevent the occurrence of feedback.

The master CUE circuit drives a meterbridge-mounted speaker through a built-in power amp, and can be programmed to interrupt the control room feed.

CUE Level Control

The CUE master level control is located at the top of the module.

The CUE level control determines the overall loudness of the cue signal as it appears in the console's cue speaker (located behind the grill in the METERBRIDGE).

Like the Control Room speakers, the cue speaker also has the potential for feedback. To avoid this situation, operator mics that mute the Control Room can also be set to mute the cue speaker.

NOTE: If cue is muted and you turn the level control all the way up, then remove the condition that has the cue muted, the sound in the cue speaker will suddenly be VERY LOUD!

SOFT KEY Buttons

These six switches and indicating LEDs are designed to perform user-programmable functions. These functions, such as firing Salvos, making temporary connections, or interfacing with the logic input and output ports on system Logic I/O cards, must be configured through the optional WheatNet-IP Navigator GUI program. See the *WheatNet-IP Audio Over IP Network* manual for details.



ENCODER And TAKE Controls

The ENCODER knob serves as a Source signal selector for fader strips.

When the A or B button is pressed and held for programming, and has started to flash on the desired fader strip, the ENCODER knob is used to select the desired source. By turning this knob, the available inputs are displayed in the 8-character SOURCE display on the meterbridge for the selected channel. When the desired input source is scrolled into the SOURCE window, pressing the TAKE button will cause that source to be programmed for the selected button (A or B) on that channel. If you fail to press the TAKE, the display will revert to its original setting after a timeout of approximately four seconds, and the original source remains in effect.

This operation may be denied to a user in the Talent Access tab of the *IP Series Console Setup Tool GUI*.

Pressing and holding the ENCODER knob for several seconds will cause some software version and configuration information to be displayed across several of the channel source displays. While in this state, turning the ENCODER knob will cycle through the following items (depending on the IP-12/IP-16's software version this list may change):

- IP-12/IP-16 IP Address
- IP-12/IP-16 MAC Address
- IP-12/IP-16 Gateway Address
- IP-12/IP-16 Subnet Mask
- Console BLADE IP Address
- IP-12/IP-16 FPGA Version

In the event that you need to discuss an issue with Wheatstone Technical Support you may be asked for some or all of this information.

Source Select Switches

The Control Room monitor output has its own bank of source select switches which select the audio signal sent to the Control Room speakers and the headphones. This bank includes dedicated switches for selecting PGM (program), AUD (audition), AUX (auxiliary), or OL (off line), and two programmable sources X1 and X2. Simply press the desired switch to listen to that output bus or external source signal. The button will be lit when the monitor is assigned to its respective bus.

Programming External Source Switches

External switches X1 and X2 may be programmed to select any allowed source in the system. Press and hold the button to be programmed until it flashes, then rotate the ENCODER until the desired source appears in the channel 12/16 display, then press TAKE (which is also flashing) to finish programming the button.

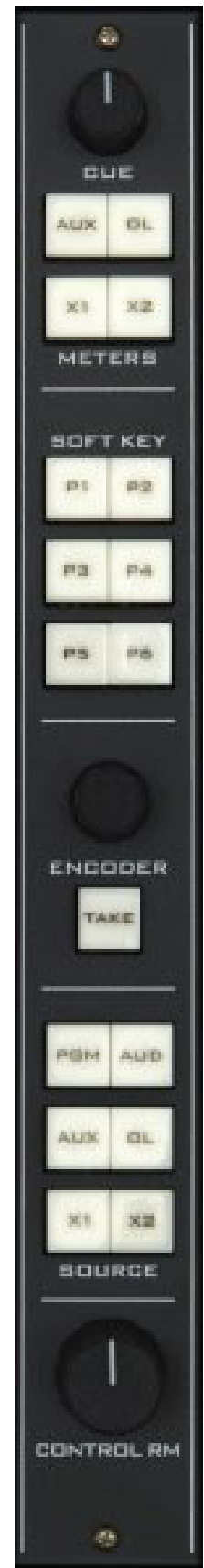

Depending on how the IP-12/IP-16 is configured, you may be able to select any source in the system or you may have a limited choice of sources for the external switches.

CONTROL ROOM Level Control

The CONTROL RM level control determines the overall loudness of the signal being monitored as it appears in the Control Room speakers. As the control is turned clockwise, the loudness increases up to a maximum at the limit of mechanical rotation. To decrease the loudness, turn the control in a counterclockwise direction.

NOTE: If the Control Room is muted and you turn the level control all the way up, then remove the condition that has the Control Room muted, the sound in the Control Room speakers will suddenly be **VERY LOUD!**

If the Control Room level has been locked in the IP-12/IP-16 configuration, the CONTROL RM knob will have no effect.

METERS

The METERS section consists of three VU meter pairs on the control surface's meterbridge and a group of METERS select buttons, located on the CR-12 module.



VU Meter Pairs

VU meter pairs (PROGRAM, AUDITION, and SWITCHED) are stereo LED bargraph type meters.

The level of the signal being metered is indicated by the number of display elements that are lighted. The more elements lighted, the stronger is the signal being displayed. The right three LEDs in each bargraph are red to indicate when the signal level is approaching a clipping (distorted) level. The next ten LEDs are yellow, indicating a normal level range, and the remaining LEDs are green. The top member of the pair indicates the level of the signal's left channel, while the bottom member of the pair indicates the level of the signal's right channel.

The left VU meter pair shows the level of the PGM output, the middle pair shows AUD output, and the right VU meter pair (SWITCHED) shows the level of the signal that is selected for it (AUX, X1, or X2). The SWITCHED meters will also display the CUE signal level when an input fader's CUE switch is activated if the IP-12/IP-16 has been so configured.

METERS Select Button

The METERS buttons select the source for the switched meter pair, as indicated above.



Studio Control Module (SC-12)

In addition to the Control Room, there may be a Studio in which one or more performers will be assembled, usually with microphones so that their voices can become part of the mix. Speakers may be provided in the Studio to allow the talent to listen to the console bus outputs at times that they are not actually on air. These speakers are fed from the control surface's stereo Studio output.

The studio monitor consists of STUDIO and HEADPHONE level controls, a TB (talkback) button, four EVENT buttons, six monitor source select buttons (PGM, AUD, AUX, OL, X1 and X2), and timer controls.

Source Select Switches

The Studio Control monitor output has its own bank of source select switches which select the audio signal sent to the Studio speakers. This bank includes dedicated switches for selecting PGM (program), AUD (audition), AUX (auxiliary), or OL (off line), and two programmable sources X1 and X2. Simply press the desired switch to listen to that output bus or external source signal. The button will be lit when the monitor is assigned to its respective bus.

Programming External Source Switches

External switches X1 and X2 may be programmed to select any allowed source in the system. Press and hold the button to be programmed until it flashes, then rotate the ENCODER on the CR-12 module until the desired source appears in the channel 12 display, then press TAKE (which is also flashing) to finish programming the button.

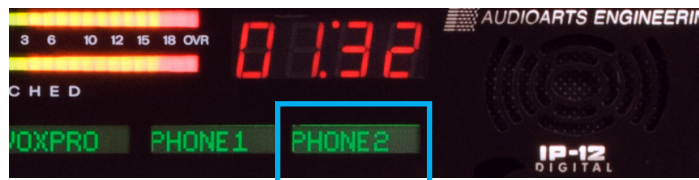

Depending on how the IP-12/IP-16 is configured, you may be able to select any source in the system or you may have a limited choice of sources for the external switches.

STUDIO Level Control

The STUDIO level control determines the overall loudness of the signal being monitored as it appears in the Studio speakers. The IP-12/IP-16 may be configured so that this level control has no effect by locking the Studio outputs on the Monitor Config tab of the *IP Series Console Setup Tool* GUI.

TB (Talkback) Button

The TB button lets the operator's microphone signal interrupt the normal feed to the studio speakers, allowing the operator to talk to the performers in the Studio. Note that the Talkback source, typically the board operator's mic, must first be cross connected to the surface's TB input.



HEADPHONE Level Control

The HEADPHONE level control determines the overall loudness of the headphone output signal, which monitors the same source (PGM, AUD, AUX, OL, X1, or X2) as the Control Room speakers.

The headphone output signal appears at the HEADPHONE JACK, located beneath the armrest near the right side of the control surface. The jack is provided as a place to plug in user-supplied **stereo** headphones having an impedance of **60 Ohms or higher**.

The IP-12/IP-16 may be configured so that the HEADPHONE level control has no effect.

TIMER Buttons

The control surface timer is provided with an AUTO-RESTART function so that input modules can automatically reset the timer display (located on the meterbridge) to zero and start a new count, allowing the announcer to easily track his own pace. The AUTO button must be lit to enable this function, and signals must be configured as well to determine which ones, if any, will trigger the auto restart.

The S/S (start/stop) button halts the timer, holds the last count, and then restarts and accumulates the count when depressed again—perfect for compiling tapes of desired duration.

RESET has a dual-mode capability:

- if you depress it while the timer is counting, the display will instantly reset to zero and start a fresh count;
- if the timer is already stopped, depressing this button will reset the timer to zero, where it will hold until start is pressed.

The HOLD button allows you to hold the display for a longer viewing duration, while still allowing the counter to continue in the background. Releasing the button will then display the current count.

EVENT Buttons

The IP-12/IP-16 includes a snapshot save and recall feature that saves all of the surface's switch settings to a unique Event file. These saved Events may be recalled as required at any time.

To recall an Event, press and hold the appropriate EVENT button 1, 2, 3, or 4 until it lights, release the button, then press it again. An Event will not change the status of a channel that is ON when the Event is recalled.

To save an Event, press and hold the appropriate EVENT button until it lights, then continue holding it until it flashes. The current surface switch settings at the time the save is done will be reestablished when that Event is recalled, except for any channels that are on at the time of recall.

User access privileges may be configured to limit access to Save and/or Take Events in the Talent Access tab of the *IP Series Console Setup Tool* GUI.



WheatNet-IP 88cb Console BLADE 3

Chapter Contents

General Information	4-2
Installation Tips	4-2
Energizing	4-3
I/O Connections	4-4
Inputs.....	4-4
Outputs.....	4-6
Logic Ports	4-7
Console BLADE 3 88cb - Input/Output Pinout Drawing	4-8
Front Panel Metering.....	4-9
Front Panel Dual OLED's	4-9
Stand Alone System Setup.....	4-10
BLADE3 Setup Mode	4-10
BLADE3 SFront Panel Configuration	4-13
Front Panel Menu Diagram.....	4-15



WheatNet-IP 88cb Console BLADE3

General Information

WheatNet-IP 88cb integrates a powerful mix engine with analog and digital I/O to give you a single rack-space console solution. Paired with the IP-12/IP-16 control surface, you have a super-compact, ultra powerful-mix station that functions as a stand-alone console. A powerful 1RU device containing the console's digital signal processing, input, output, and logic circuitry, the engine has no fans and may be located either next to the control surface or at a remote location.

WARNING! Under no circumstances should the WheatNet-IP unit be opened! The unit contains high voltage circuits that are hazardous and potentially harmful. The unit has no user-serviceable parts inside! If you have a problem the unit must be returned to Wheatstone Corporation for repair.

Installation Tips

- Place any surge protection circuits as close as possible to the WheatNet-IP or other device being protected.
- Establish a low impedance common ground in your facility and try to route all grounds to that point.
- Choose the best power conditioning / UPS units that you can afford and suitable for your equipment – focus on the features and options you need. The better UPS products can prevent thousands of dollars in equipment damage – some even come with an external equipment damage warranty.
- Unbalanced analog audio connections to the Console BLADE3 RJ-45 connectors can be done in different ways. The following wiring methods are worthy of consideration:
 - connections can be made with UTP (unshielded twisted pair) cable such as CAT5
 - for an audio input to the BLADE3, connect the unbalanced source hot wire (for example, the center pin of an RCA connector) to the RJ-45 HI pin, and connect the unbalanced source ground (for example, the shell of an RCA connector) to the RJ-45 LO pin
 - for an audio output from the BLADE3, the same connections can be made as are used for the inputs
 - although not recommended, connections can be made with shielded twisted pairs, such as is normally used for balanced analog audio connection
 - for an audio input to the BLADE3, connect the unbalanced source hot wire to one wire of the twisted pair and the unbalanced source ground to the other wire of the pair – at the BLADE3 end, connect the wire carrying the hot signal to the RJ-45 HI pin and the wire carrying the ground to the RJ-45 LO pin – connect

the shield to a convenient ground connection at one end only – typically when equipment is being connected in this fashion you choose to make your ground connection consistently at either the source or the destination, using the same grounding scheme wherever in the system such connections are made

- for an audio output from the BLADE3, the same connections can be made as are used for the inputs
 - adapters are commercially available with RJ-45 connectors on one end and the appropriate audio connector type, such as RTS or XLR, on the other
 - balanced to unbalanced adapters, also called baluns, are commercially available to transform the unbalanced connection to a balanced connection – these are usually active devices and will account for level differences as well as converting between balanced and unbalanced connections
- For digital audio connections always use a good quality digital audio cable with a characteristic impedance of 110 ohms.

The AES/EBU specification, with its broad impedance tolerance, allows for cables with impedances from 88 ohms to 132 ohms – 110 ohms is ideal. Twisted pair cable should be shielded, and in the case of multi-pair cable, each pair should be individually shielded. Foil shielding is recommended for permanent installations and foil shield plus overall braid should be used in applications where frequent flexing of the cable will occur. One cable pair is capable of carrying two channels of digital audio.

Generic “audio” cable such as Belden 8451 *may* be used for interconnecting AES3 digital audio devices but **only** for distances of less than about 25 feet. The actual cable length that will work satisfactorily in an installation is primarily determined by the error correction and jitter tolerance of the AES3 receiver device and the cable used.

The impedance of most “analog” cables ranges from 40 ohms to 70 ohms and represents a large impedance mismatch from the nominal 110 ohms required in the AES3 standard. Such mismatch will result in signal reflections, causing bit errors at the AES3 receiver. The higher capacitance of generic analog cables also slows down the rise time of the digital data signals, impairing the ability of the AES3 receiver to accurately detect digital signal transitions. This may result in increased jitter.

Energizing

There is no power switch. The AC line input voltage is permitted to be between 90 and 260VAC, 50 or 60Hz. Power consumption is under 100VA.

Aggressive AC input filtering is utilized at the AC input of the WheatNet-IP; however, it is always advisable to use external surge protection and/or an uninterruptible power supply (UPS), especially where AC power quality is questionable, such as at a remote transmitter site.

Power conditioning, surge suppression, and even power backup devices are wise investments when using sensitive modern electronic devices that use an internal computer.

Use of a UPS (uninterruptible power supply) is a good idea and will protect the WheatNet-IP from short duration power interruptions which may cause it to reboot. During boot up, audio is interrupted for approximately 40 seconds.

I/O Connections



Two female XLR connectors are microphone preamplifier inputs. Recessed rear panel phantom power switches and gain trims can be independently configured, and one RJ-45 connector connects the preamp outputs to any one of the Analog Input RJ-45's.

Eight RJ-45 connectors are for audio inputs. The first four RJ-45 jacks are analog inputs which can be set up as four stereo, eight mono, or any combination of stereo and mono. The last four RJ-45 jacks are AES digital inputs.

The Console BLADE3 also has eight RJ-45 connectors for audio outputs. The first four RJ-45 jacks are set up as analog stereo outputs, and the last four RJ-45 jacks are set up as AES digital outputs. The “Console” template, by default, has a signal map that automatically cross connects the surface’s Program, Headphone, Cue, and Studio signals to the designated outputs. The Digital outputs follow the Analog outputs and cannot be independently connected to different audio sources.

An RJ-45 and four 1/4" jacks are provided for headphone and cue outputs.

Four XLR male connectors are provided for control room and studio outputs.

The BLADE3 also has two more RJ-45 connectors to provide 12 logic ports, which can be individually designated during setup as inputs or outputs. These ports are where you wire the various external switches, indicators, and control functions you need in your facility.

There are two RJ-45 jacks for Ethernet. One is for 1 Gigabit Ethernet – connect this one to your network. The 100 Megabit Ethernet port is not used – do not connect anything to this port.

Consult the wiring diagram on page 4-8 for detailed information.

The unit has a standard IEC power connector. The BLADE3 has an internal power supply that will accept 100-240 volts 50/60 hertz AC power.

Inputs

The WheatNet-IP 88cb can be fed from three different types of inputs: microphone, analog line level, and AES-3 digital.

When processing mic level (-50dBu nominal) inputs, the input to the internal microphone preamplifiers is fed from one of the two female XLR connectors. When using the internal microphone preamplifiers, a jumper must be connected from the MIC OUTS RJ-45 to a selected Analog input (1-4). The mic preamps have recessed single-turn trimpots to set gain, up to a maximum of 70dB, and display remarkably high performance and accuracy. Phantom power is available via recessed rear panel switches.

Four RJ-45 connectors can be used for analog line level inputs. The line level analog audio inputs are +4dBu balanced. The analog line inputs exhibit a bridging impedance and can handle signals up to +20dBu.

The digital inputs of the WheatNet-IP 88cb (inputs 5-8) will accommodate digital inputs having a wide range of sample rates. These inputs will be sample rate converted to the system's chosen sample rate of 44.1kHz or 48kHz, which is set in the *System Wizard* when bringing up the BLADE3 after a Factory Reset (or when first setting the BLADE3 up out of the box), or via the optional WheatNet-IP Navigator GUI. The GUI also allows you to select input 8 of the digital BLADE3, or of any BLADE3 that has a digital input as input 8, to be a primary external reference, and a digital input 8 from a different BLADE3 to be a secondary external reference. Please note that the sample rate of a digital input 8 should be the same, either 44.1kHz or 48kHz, as the system's chosen sample rate.

AES sources are by design stereo; if the BLADE3 is not set to be stereo the appropriate Left or Right signal within the AES stream will be applied to the signal path.

MIC IN XLR

XLR#1 Pin 1 – SH	}	Mic 1 In
XLR#1 Pin 2 – HI		
XLR#1 Pin 3 – LO		
XLR#2 Pin 1 – SH	}	Mic 2 In
XLR#2 Pin 2 – HI		
XLR#2 Pin 3 – LO		

Analog 1-4 RJ-45

RJ-45#1 Pin 1 – HI	}	Line 1 Lt In
RJ-45#1 Pin 2 – LO		
RJ-45#1 Pin 3 – HI	}	Line 1 Rt In
RJ-45#1 Pin 6 – LO		
RJ-45#2 Pin 1 – HI	}	Line 2 Lt In
RJ-45#2 Pin 2 – LO		
RJ-45#2 Pin 3 – HI	}	Line 2 Rt In
RJ-45#2 Pin 6 – LO		
RJ-45#3 Pin 1 – HI	}	Line 3 Lt In
RJ-45#3 Pin 2 – LO		
RJ-45#3 Pin 3 – HI	}	Line 3 Rt In
RJ-45#3 Pin 6 – LO		
RJ-45#4 Pin 1 – HI	}	Line 4 Lt In
RJ-45#4 Pin 2 – LO		
RJ-45#4 Pin 3 – HI	}	Line 4 Rt In
RJ-45#4 Pin 6 – LO		

Digital 5-8 RJ-45

RJ-45#5 Pin 1 – HI	}	AES 5 In
RJ-45#5 Pin 2 – LO		
RJ-45#6 Pin 1 – HI	}	AES 6 In
RJ-45#6 Pin 2 – LO		
RJ-45#7 Pin 1 – HI	}	AES 7 In
RJ-45#7 Pin 2 – LO		
RJ-45#8 Pin 1 – HI	}	AES 8 In
RJ-45#8 Pin 2 – LO		

Outputs

The WheatNet-IP 88cb provide four stereo analog outputs on RJ-45 connectors, four digital AES formatted outputs on RJ-45 connectors, cue and headphone outputs on an RJ-45 connector and on 1/4" jacks, and control room and studio monitor outputs on XLR male connectors.

MIC OUTS RJ-45

RJ-45 Pin 1 – HI]	Mic 1 Out
RJ-45 Pin 2 – LO		
RJ-45 Pin 3 – HI]	Mic 2 Out
RJ-45 Pin 6 – LO		



When using the microphone preamplifiers, a jumper must be connected from the MIC OUTS to the desired analog input port (1-4).

CUE/HDPN OUT RJ-45

RJ-45 Pin 1 – HI]	HDPN Lt Out
RJ-45 Pin 2 – LO		
RJ-45 Pin 3 – HI]	HDPN Rt Out
RJ-45 Pin 6 – LO		
RJ-45 Pin 4 – HI]	Cue Lt Out
RJ-45 Pin 5 – LO		
RJ-45 Pin 7 – HI]	Cue Rt Out
RJ-45 Pin 8 – LO		

STUDIO OUT XLR

XLR#1 Pin 1 – SH]	Studio Lt Out
XLR#1 Pin 2 – HI		
XLR#1 Pin 3 – LO		
XLR#2 Pin 1 – SH]	Studio Rt Out
XLR#2 Pin 2 – HI		
XLR#2 Pin 3 – LO		

CR OUT XLR

XLR#1 Pin 1 – SH]	CR Lt Out
XLR#1 Pin 2 – HI		
XLR#1 Pin 3 – LO		
XLR#2 Pin 1 – SH]	CR Rt Out
XLR#2 Pin 2 – HI		
XLR#2 Pin 3 – LO		

PGM OUT ANALOG RJ-45

RJ-45 A Pin 1 – HI]	PGM A Lt Out
RJ-45 A Pin 2 – LO		
RJ-45 A Pin 3 – HI]	PGM A Rt Out
RJ-45 A Pin 6 – LO		
RJ-45 B Pin 1 – HI]	PGM B Lt Out
RJ-45 B Pin 2 – LO		
RJ-45 B Pin 3 – HI]	PGM B Rt Out
RJ-45 B Pin 6 – LO		

RJ-45 C Pin 1 – HI	}	PGM C Lt Out
RJ-45 C Pin 2 – LO		
RJ-45 C Pin 3 – HI	}	PGM C Rt Out
RJ-45 C Pin 6 – LO		
RJ-45 D Pin 1 – HI	}	PGM D Lt Out
RJ-45 D Pin 2 – LO		
RJ-45 D Pin 3 – HI	}	PGM D Rt Out
RJ-45 D Pin 6 – LO		

PGM OUT DIGITAL RJ-45

RJ-45 A Pin 1 – HI	}	PGM AES A Out
RJ-45 A Pin 2 – LO		
RJ-45 B Pin 1 – HI	}	PGM AES B Out
RJ-45 B Pin 2 – LO		
RJ-45 C Pin 1 – HI	}	PGM AES C Out
RJ-45 C Pin 2 – LO		
RJ-45 D Pin 1 – HI	}	PGM AES D Out
RJ-45 D Pin 2 – LO		

Logic Ports

The WheatNet-IP 88cb has two LOGIC I/O RJ-45 connectors that provide 12 Universal logic ports.

LOGIC I/O 1 - 6 RJ-45

RJ-45 Pin 1 – Digital Ground
RJ-45 Pin 2 – Logic 1 In/Out
RJ-45 Pin 3 – Logic 2 In/Out
RJ-45 Pin 4 – Logic 3 In/Out
RJ-45 Pin 5 – Logic 4 In/Out
RJ-45 Pin 6 – Logic 5 In/Out
RJ-45 Pin 7 – Logic 6 In/Out
RJ-45 Pin 8 – +5V Digital

LOGIC I/O 7 - 12 RJ-45

RJ-45 Pin 1 – Digital Ground
RJ-45 Pin 2 – Logic 7 In/Out
RJ-45 Pin 3 – Logic 8 In/Out
RJ-45 Pin 4 – Logic 9 In/Out
RJ-45 Pin 5 – Logic 10 In/Out
RJ-45 Pin 6 – Logic 11 In/Out
RJ-45 Pin 7 – Logic 12 In/Out
RJ-45 Pin 8 – +5V Digital

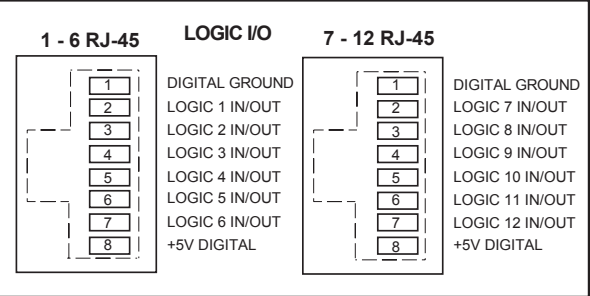
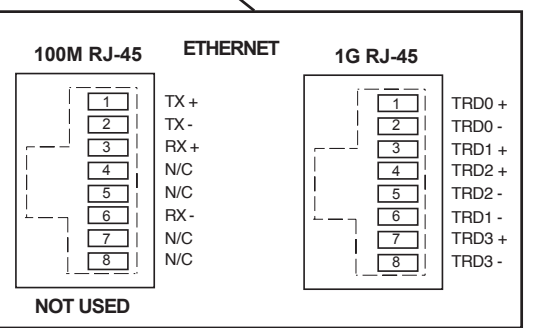
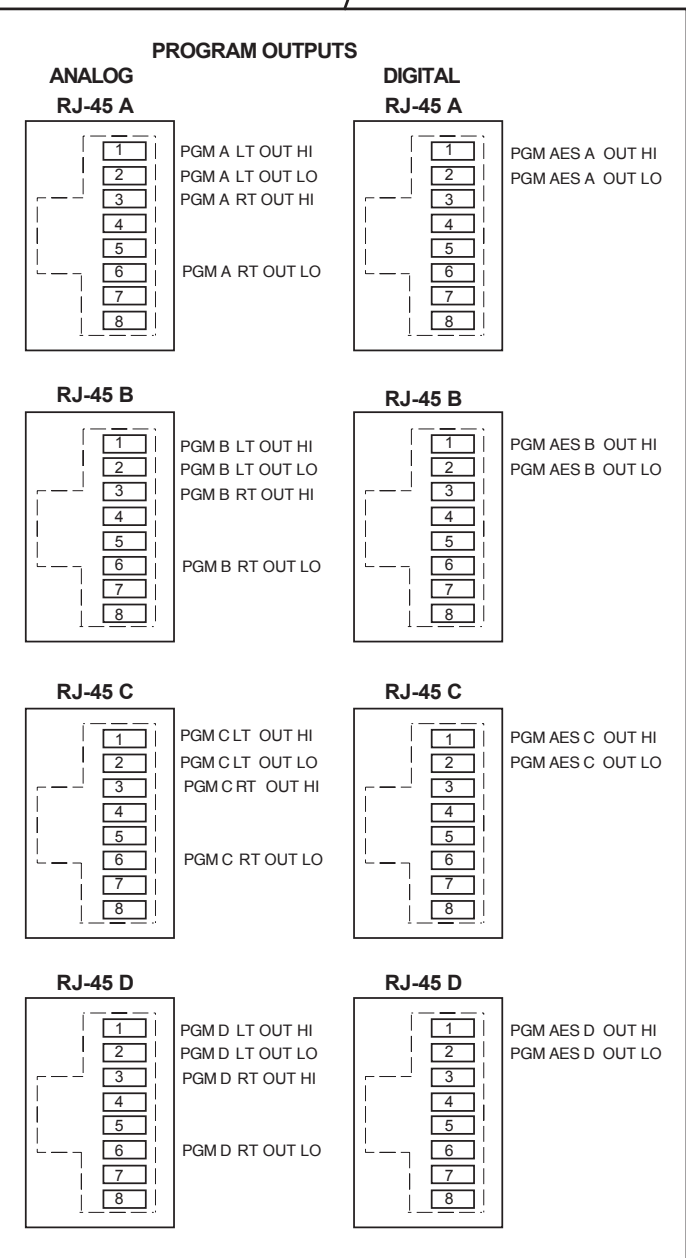
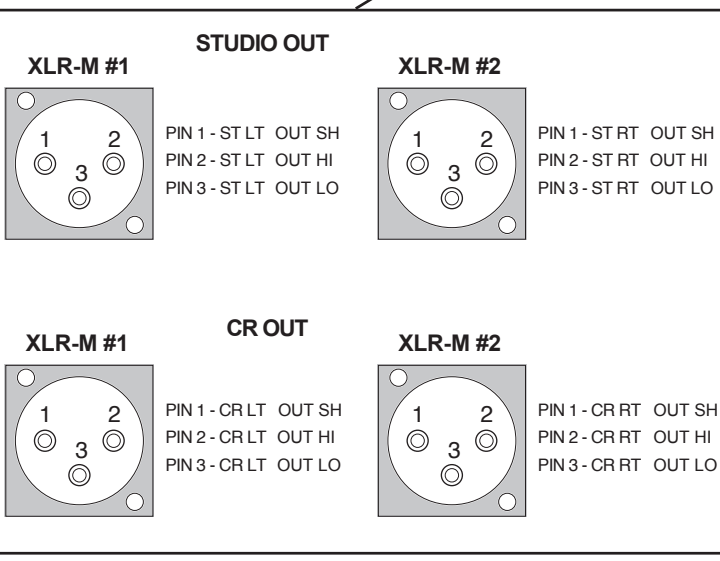
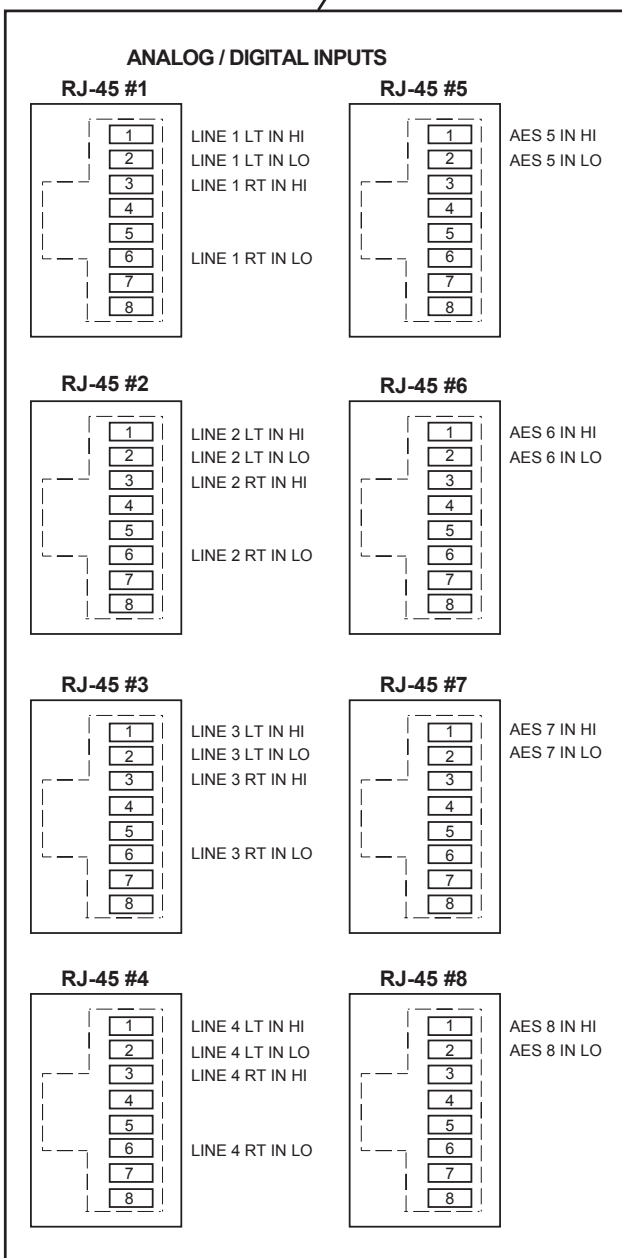
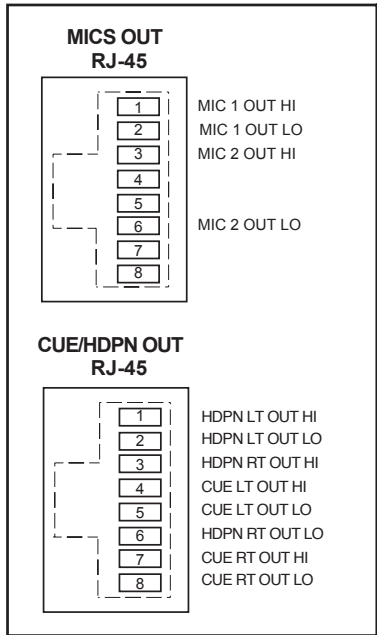
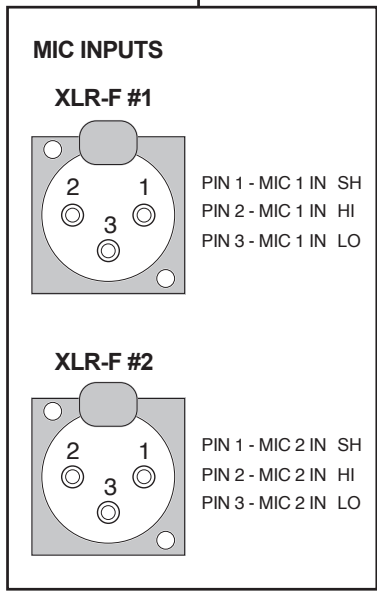

NOTE: CUE/HDPN OUT RJ-45 and 1/4" jacks audio connections are paralleled. Either may be used.

Front Panel Metering



The front panel of each BLADE 3 model houses metering for every input or output on the BLADE – 12-segment, multi-color LEDs that can be used for metering inputs and outputs as 8 pairs or 16 mono signals. The exception to this is the IP88m Mic unit, which meters eight mono input signals. Please note that these meters show audio levels after any gain trimming has been applied, so if for some reason you have the gain for a particular channel cranked down, you may not see any meter indication even though audio is there.

Front panel logic indicators show status for active logic and direction (in or out) of the BLADE 3.

There also four system indicators:

- Link – Shows network connectivity.
- Route Master – Lights to show that the BLADE 3 is functioning as the System Master.
- Clock Master – Lights to show that the BLADE 3 is functioning as the system’s Clock Master.
- Error – Shows an error in network connectivity.

Front Panel Dual OLED’s

New BLADE 3s come with dual OLED displays for monitoring and control of most functions right from the front panel, including audio routing setup, monitoring, network information, alarm status, enabling and operating utility mixes, setting input and output gain, and connecting audio processing. Settings can also be done remotely using a PC.



The front panel’s two OLED displays, two buttons, and the knob quickly and easily allow you to set up and configure each BLADE 3 unit.

Rotation of the knob navigates up and down a menu when there is a list, or scrolls thru options in a submenu once one has been selected. Pressing the right arrow button navigates through sub-menu options. Pushing the right arrow button or the knob “takes” an option. The <---> button backs out of a submenu to the main menu.

Use of the controls will become clearer as we go through some examples.

Stand Alone System Setup

When shipped from the factory the Console BLADE 3 and IP-12/IP-16 are preconfigured in **stand alone** mode. To use a BLADE 3 in stand alone mode is easy. Just connect your audio and logic inputs and outputs and turn it on. When shipped from the factory the Wheat-Net-IP 88cb is preconfigured with an IP address of 192.168.87.101 and the control surface is preconfigured with an IP address of 192.168.87.201.

If you are adding BLADE 3 and IP-12/IP-16 to an existing system you will need to do a factory reset to set the BLADE 3 to a different IP Address and reset the IP-12/IP-16 configuration. After factory reset the BLADE 3 will enter the **Blade Setup** mode. That's where you tell the BLADE 3 what you want it to do by means of the front panel knob and switches. If you have any issues during the setup process please contact Wheatstone Technical Support for further assistance at (252) 638-7000.

BLADE 3 Setup Mode

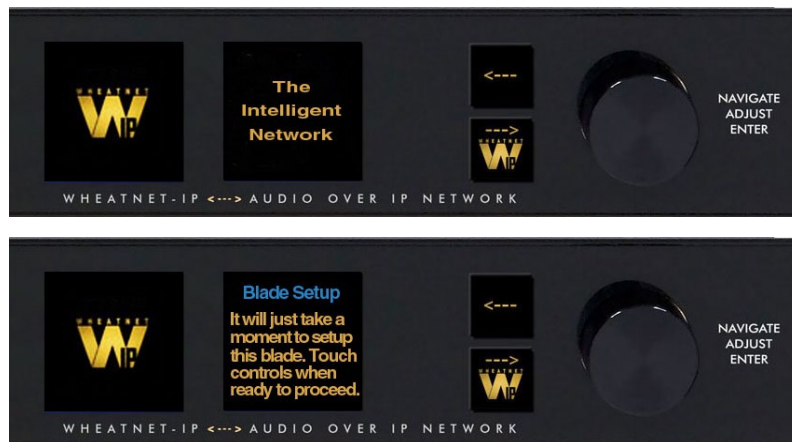

Activating any of the front panel controls will begin the setup process, during which you will be faced with a small number of choices, as indicated on the right side OLED display.

Your first decision involves “System Size” and is something that should be well thought out before doing **Blade Setup** on your first BLADE 3. Here are the two choices, and their significance:

1-99 Blades – This would be your choice for a small to medium sized system. When you choose this size the setup wizard will automatically assign network settings to the BLADE 3 based on your choice of Blade ID (see below). IP addresses will be assigned within the 192.168.87.xxx subnet, with the last octet being assigned a value of 100 plus the Blade ID. The subnet mask will be set to 255.255.255.0, and the gateway will be set to 192.168.87.1. Once you have gone through the complete Blade Setup process you will be able to change the network settings, if desired. If you are setting up a system that you know will never grow beyond 99 BLADE 3 units, then this is your best choice.

100+ Blades – This would be your choice for a large system. When you choose this size the setup wizard will automatically assign network settings to the BLADE 3 based on your choice of Blade ID. For IDs in the range of 1 to 99, IP addresses will be assigned within the 192.168.87.xxx subnet, with the last octet being assigned a value of 100 plus the Blade ID. The subnet mask will be set to 255.255.0.0, and the gateway will be set to 192.168.87.1. For IDs in the range of 100 to 199, IP addresses will be assigned within the 192.168.88.xxx subnet, with the last octet being assigned a value equal to the

Blade ID. The subnet mask will be set to 255.255.0.0, and the gateway will be set to 192.168.88.1. Once you have gone through the complete Blade Setup process you will be able to change the network settings, if desired. If you are setting up a system with more than 100 BLADE 3 units, or a system that you know will grow beyond 99 BLADE 3 units in the future, then this is your best choice.

Scroll the knob to the desired system size and click the right arrow button to accept that size. If you have chosen either **1-99 Blades** or **100+ Blades** you will then need to select a BLADE 3 Blade ID. Note that each BLADE 3 in the system must have a unique Blade ID.

Once you have completed the decision process for system size, the setup wizard will display the settings on the right side OLED display. Press the right arrow button to advance to the next decision, that of **Default Sample Rate**. Here there are only two choices: **48K** (48kHz), or **44K** (44.1kHz). If you are not sure which one to select, and you are not working with audio for television, use **44K**. You can change the sample rate at a later time if needed. Scroll to the desired selection and press the right arrow button.

The final choice you need to make is which **I/O Template** to use. Here are the three choices, and their significance:

Stereo I/O – This would be the most common choice if your facility consists primarily of equipment with stereo inputs and outputs, such as tape machines, CD players, computers, etc. When this template is employed the setup wizard will configure the inputs and outputs of the BLADE 3 as stereo signals and add these signals to the system. If you choose this template, you can later on change some of your signals to mono if necessary.

Mono I/O – This would be the most common choice if your facility consists primarily of monophonic equipment, such as microphones, phone systems, etc. When this template is employed the setup wizard will configure the inputs and outputs of the BLADE 3 as mono signals and add these signals to the system. If you choose this template, you can later on change some of your signals to stereo if necessary. Please note that if you have a lot of mono sources you may be tempted to use this template, but you should also consider the rest of your audio equipment; you may actually still have more stereo signal requirements than mono ones.

Custom – This would be a tempting choice if you have a fairly even balance between mono and stereo signals in your facility. However, if you choose this template the setup wizard will not configure the BLADE 3 inputs, nor will it add input signals to the system. With this template, you will need to create the signals for each input connection.

Once all the choices have been made, the setup wizard will complete the configuration process. The right side OLED display will indicate that the BLADE 3 is entering the system:



Once the BLADE 3 has joined the system its basic information will show on the OLED displays:



When the front panel controls are idle for a while the OLED displays will show the Screen Saver:



BLADE 3 Front Panel Configuration



Activating any of the front panel controls will replace the screen saver display with the main menu screen.



Press the left arrow button  twice to open up the BLADE 3 information screens:

On the left window of the Info screens you will find your digital system clock rate, that can be either 44.1K, 48K, External Reference, or AES 67. The “Master” on the top row will be displayed if this BLADE 3 assumes the role as system master over the rest of the BLADE 3s in your network, or a square wave icon shows if this BLADE 3 is acting as the clock master. The BLADE 3’s Name, ID number, and inside temperature also display in this window. The RJ-45 connector icon will show green and have moving dots next to it if the BLADE 3 is connected to the network. If it is not connected the RJ-45 icon will show red and there will be no dots.



The right window of the Info screens displays whether the BLADE 3’s signal meters are displaying input or output, and also shows the BLADE 3 IP Address and Uptime.

Pressing the left arrow button again will take you back to the screen saver display.

Clockwise rotation of the knob navigates up and down a menu when there is a list, or scrolls thru options in a submenu once one has been selected. Pressing the right arrow button  navigates through sub-menu options. Pushing the knob “takes” an option.

To edit any parameter or name, press the right arrow button to highlight the parameter. Turn the knob to find the desired value or character, then press the right arrow button to take it. If the parameter has more than one field you can press the knob to cycle through the fields.

The  button backs out of a submenu to the main menu.

For example, when you select *Headphone...* by pressing the right arrow button the main menu list will be displayed in the left window and *Headphone Level* and *Connected Status* show in the right window.



To adjust the volume level, turn the knob to highlight *Headphone*

Level and push the knob. You can then adjust the volume to a safe and comfortable level by turning the knob. Once complete, push the knob to exit the adjustment mode.

Press the  button to get back to the main menu.

For *Gain Levels...* select *Sources...* or *Destination...*



that brings up screens with list of sources (shown) or destinations and gain levels.



Try your hand at making some adjustments to help you get more familiar with the front panel controls.

The main menu of the BLADE 3 shows all of the options available from the front panel. These options are:

- **Headphone...** – Selects the headphone source and volume level.
- **Inputs...** – Sets the gain structure and phantom power (BLADE 3 Mic type only).
- **Blade...** – Displays current info of the BLADE 3, software and hardware version, external clock reference, and network settings. These settings can also be edited from this submenu.
- **Display...** – Sets the display's brightness and screen saver time.
- **Gain Levels...** – Displays the gain levels for selected sources and destinations and allows the user to set the input level for each source and destination.
- **Utility Mixer...** – Each BLADE 3 has two Utility Mixers. Their features include panning, channel On/OFF, fader levels, and access to any source signal in the system. They also include a full ACI (Automation Control Interface) allowing remote control, ducking, auto fade, channel on/off, levels, source assign, etc.
- **Routing...** – Routes any audio input to any output or all outputs.
- **Status...** – Displays Uptime, Runtime, Date/Time, Temperature, ANNC Pkts/Errors, LIO Pkts/Errors, and GUI information, Surface availability (BLADE 3 Engine or Console types only), Route and Clock Master status.
- **Meters...** – Sets the front panel meter mode for BLADE 3 to show the input signal levels for each source or output signal levels for each destination.
- **Logic...** – Displays LIO Status and allows testing of the LIO outputs.
- **Password...** – Allows you to set a password to secure front panel access.

Front Panel Menu Diagram

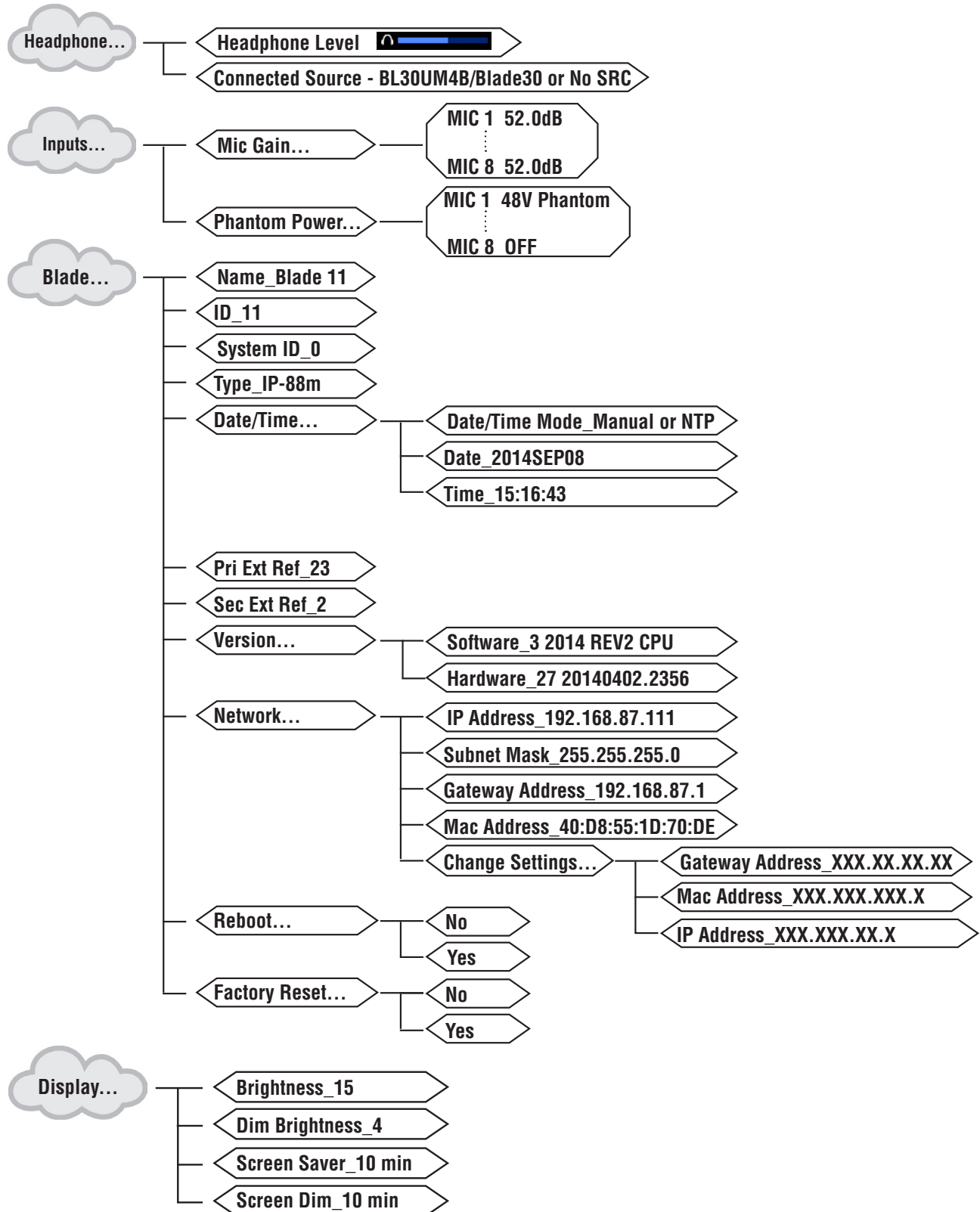

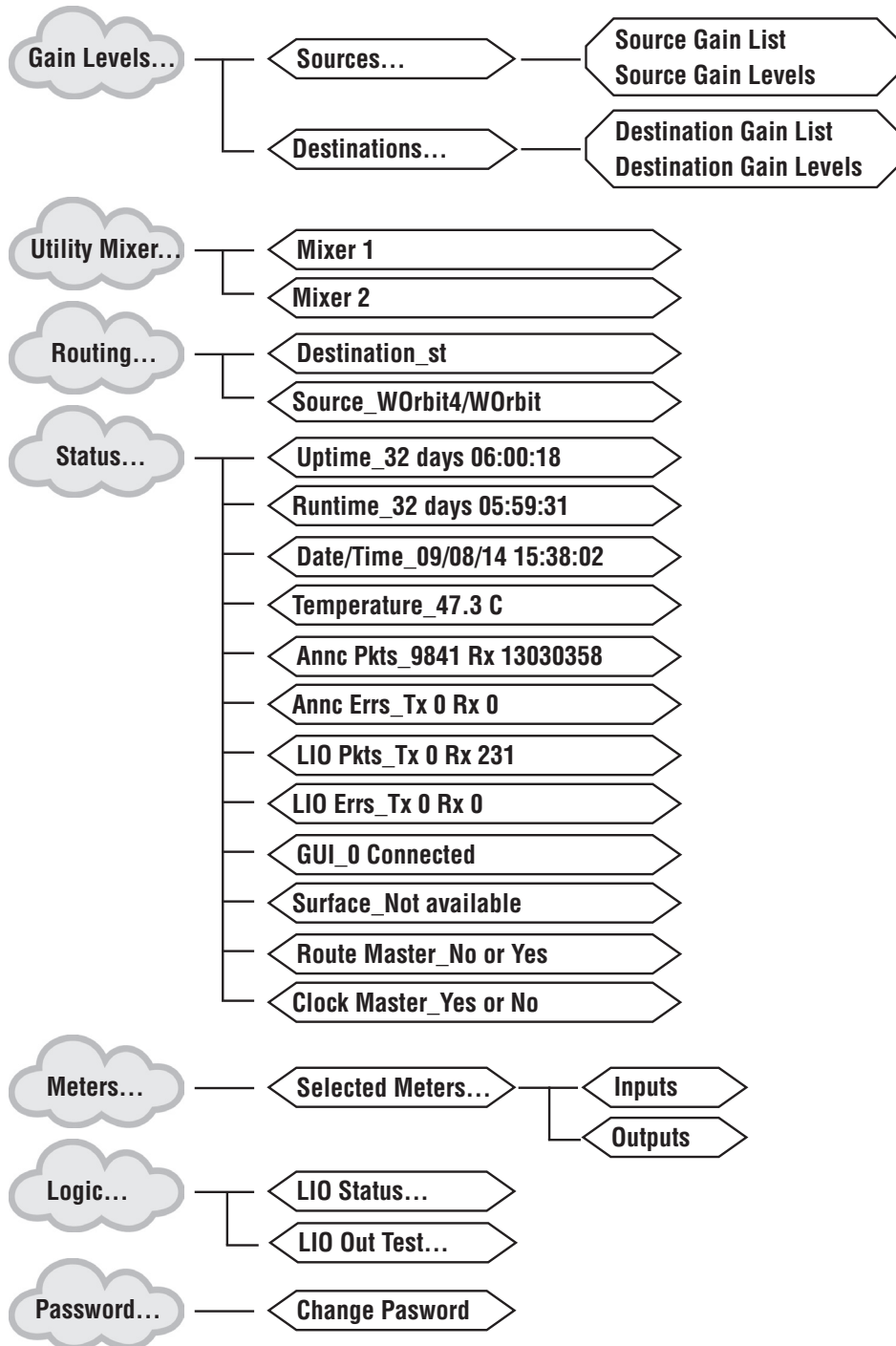

Host CPU (HC-12)

Chapter Contents

Overview	5-2
Ethernet IP Addressing	5-2
Ethernet Interface Wiring	5-2
Hook-Ups	5-3
“CT20” RJ-45 - Main Ethernet Connector	5-3
Typical Straight-Through Cable.....	5-3

Host Controller (HC-12)

Overview

The host controller provides the centralized intelligence for the IP-12/IP-16 control surface. The HC-12 communicates to the Console BLADE3 via TCP/IP over Ethernet through a standard ethernet hub or switch.

Hardware and software configuration, as well as real time crosspoint information, is saved in non-volatile storage on the HC-12 card and is restored at power up or reset. This configuration information provides details to the host application running on the HC-12, such as the specific audio hardware available.

Ethernet IP Addressing

The Wheatstone IP-12/IP-16 control surface ships with the host controller IP address set to 192.168.87.201. Stand-alone systems (not interfaced to a station's existing network) require no IP address changes.

Ethernet Interface Wiring

Networked systems are connected to the network hub or switch via a straight (pin to pin) CAT5 cable. Typical CAT5 cable pinouts are included in the "Hook-Ups" section later in this chapter. This connection is for communicating with the Console BLADE3, any other BLADE3 or controllers in the system, and the configuration computer.

Hook-Ups

The “CT20” RJ-45 connector for Ethernet connection is located on the center of the bottom side of the HC-12 PCB.

“CT20” RJ-45 – ETHERNET CONNECTOR

- PIN 1 – TXD +
- PIN 2 – TXD -
- PIN 3 – RXD +
- PIN 4 – N/C
- PIN 5 – N/C
- PIN 6 – RXD -
- PIN 7 – N/C
- PIN 8 – N/C

*Ethernet Connector
(RJ-45)*

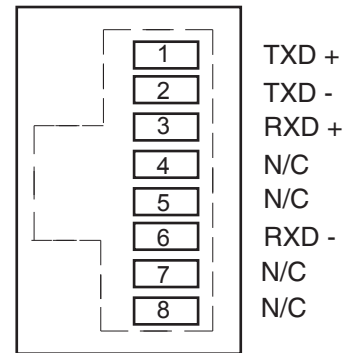

Typical Straight-Through Cable

	PIN		PIN	
	White/Orange 1	TXD +	1	White/Orange
	Orange 2	TXD -	2	Orange
<i>RJ-45 Plug</i>	White/Green 3	RXD +	3	White/Green
	Blue 4	N/C	4	Blue
	White/Blue 5	N/C	5	White/Blue
	Green 6	RXD -	6	Green
	White/Brown 7	N/C	7	White/Brown
	Brown 8	N/C	8	Brown

RJ-45 Plug

Used for connecting the host controller to your network hub.

Schematic and Load Sheet Drawings

Chapter Contents

INSW-12 Input Module Switch Card

Schematic 6-2

Load Sheet 6-3

ONSW-12 Input Module On/Off Switch Card

Schematic 6-4

Load Sheet 6-5

CRSW-12 Control Room Module Switch Card

Schematic 6-6

Load Sheet 6-7

SCSW-12 Studio Control Module Switch Card

Schematic 6-8

Load Sheet 6-9

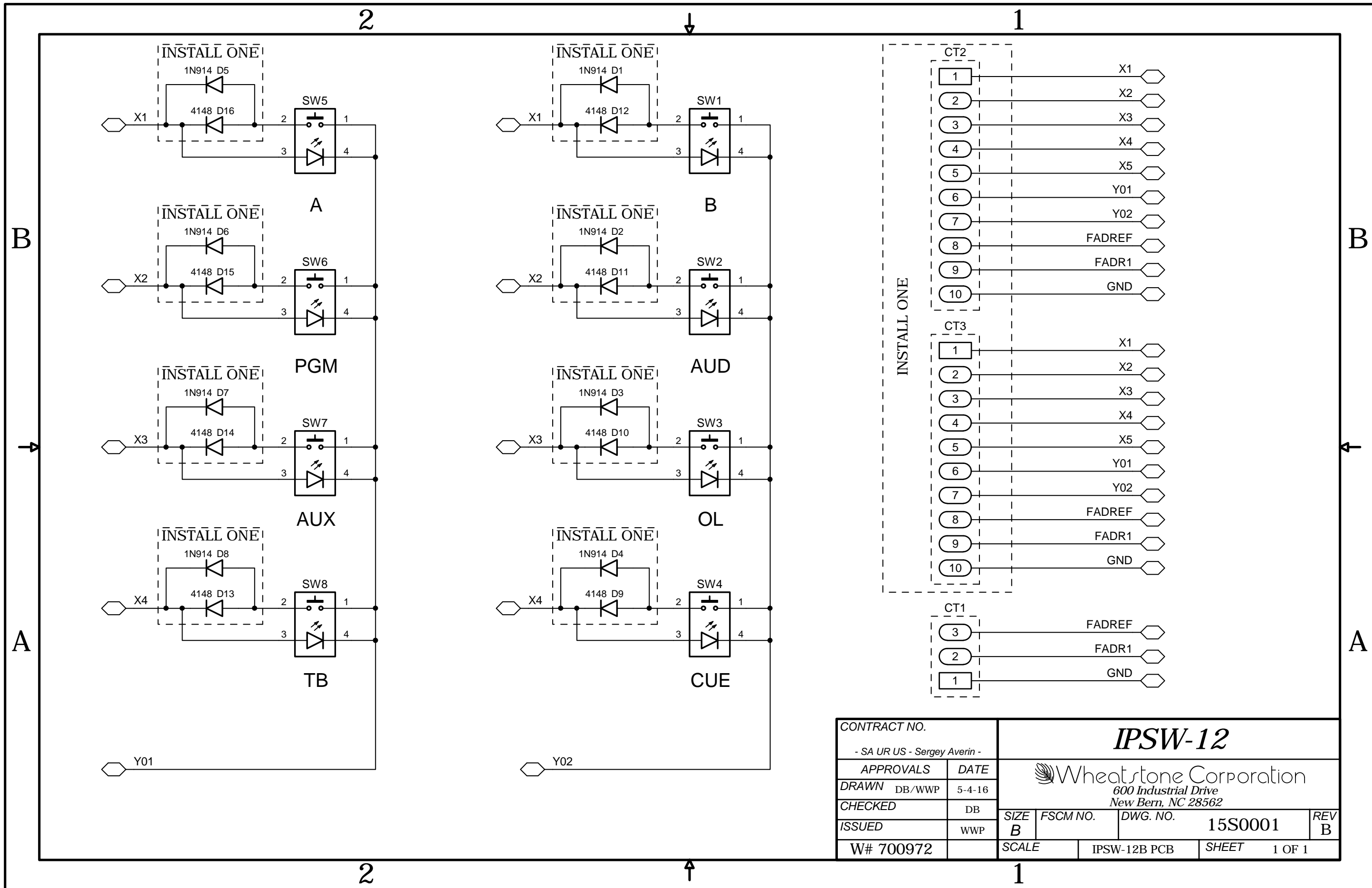

CONTRACT NO.		IPSW-12			
- SA UR US - Sergey Averin -					
APPROVALS	DATE	 Wheatstone Corporation 600 Industrial Drive New Bern, NC 28562			
DRAWN DB/WWP	5-4-16				
CHECKED	DB	SIZE	FSCM NO.	DWG. NO.	REV
ISSUED	WWP	B		15S0001	B
W# 700972		SCALE	IPSW-12B PCB	SHEET	1 OF 1

INSW-12 Input Module Switch Card Schematic - Sheet 1 of 1

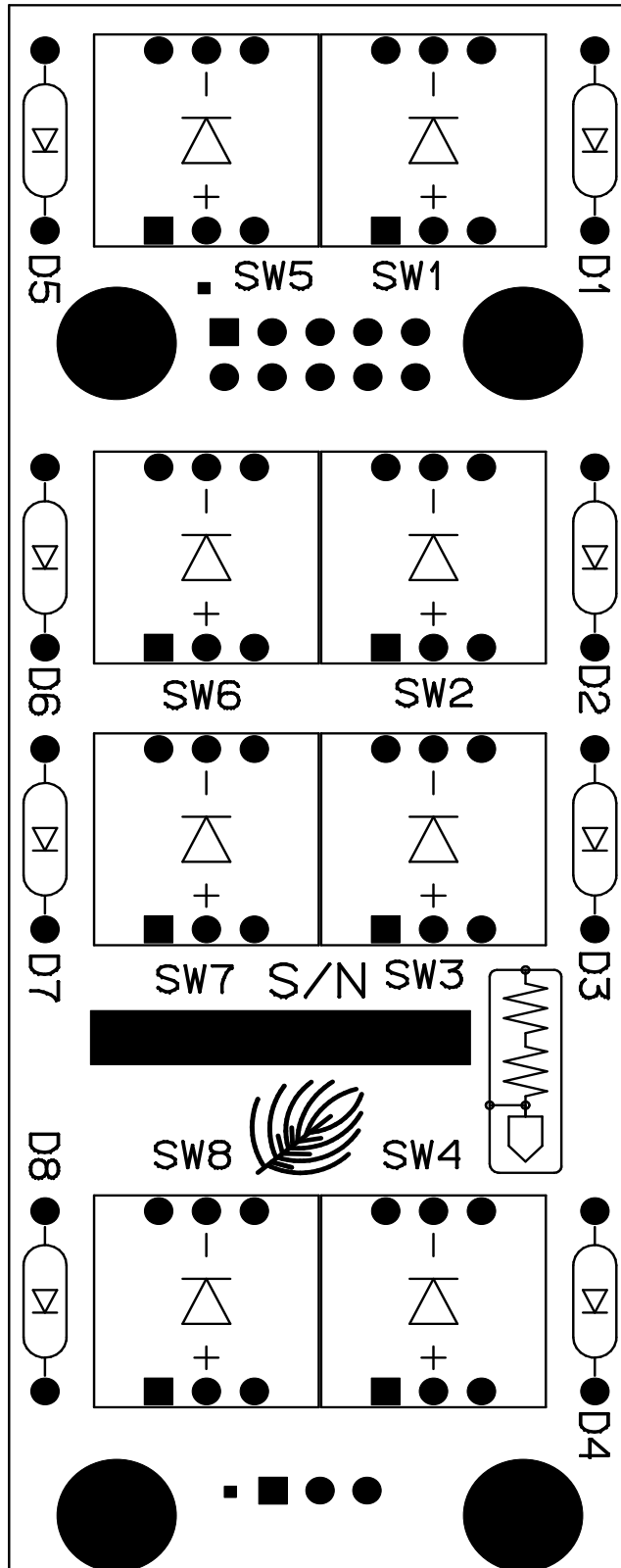

INSW-12 Input Module Switch Card Load Sheet

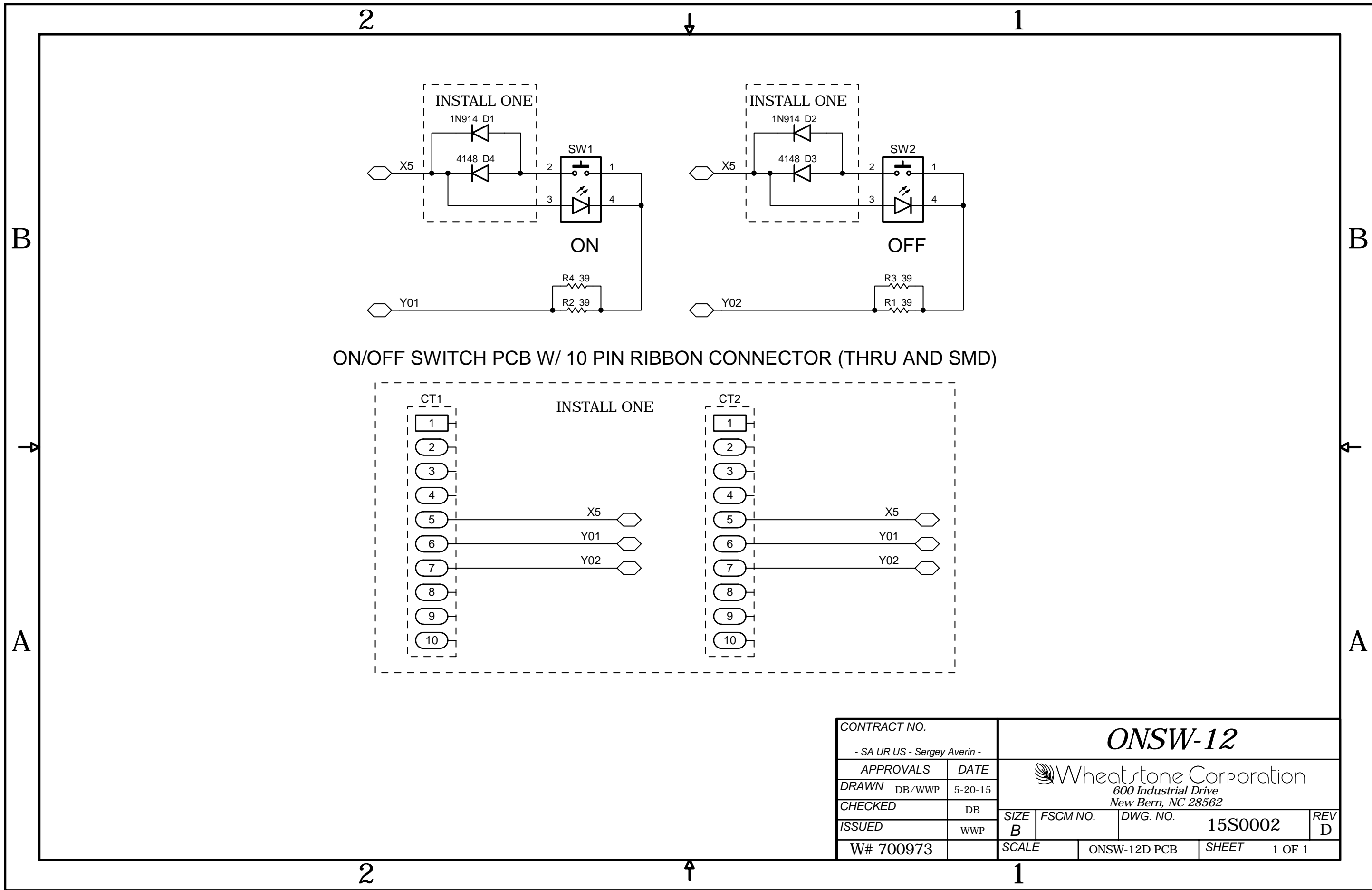

CONTRACT NO. - SA UR US - Sergey Averin -		ONSW-12			
APPROVALS	DATE	 Wheatstone Corporation 600 Industrial Drive New Bern, NC 28562			
DRAWN DB/WWP	5-20-15				
CHECKED	DB	SIZE	FSCM NO.	DWG. NO.	REV
ISSUED	WWP	B		15S0002	D
W# 700973		SCALE	ONSW-12D PCB	SHEET	1 OF 1

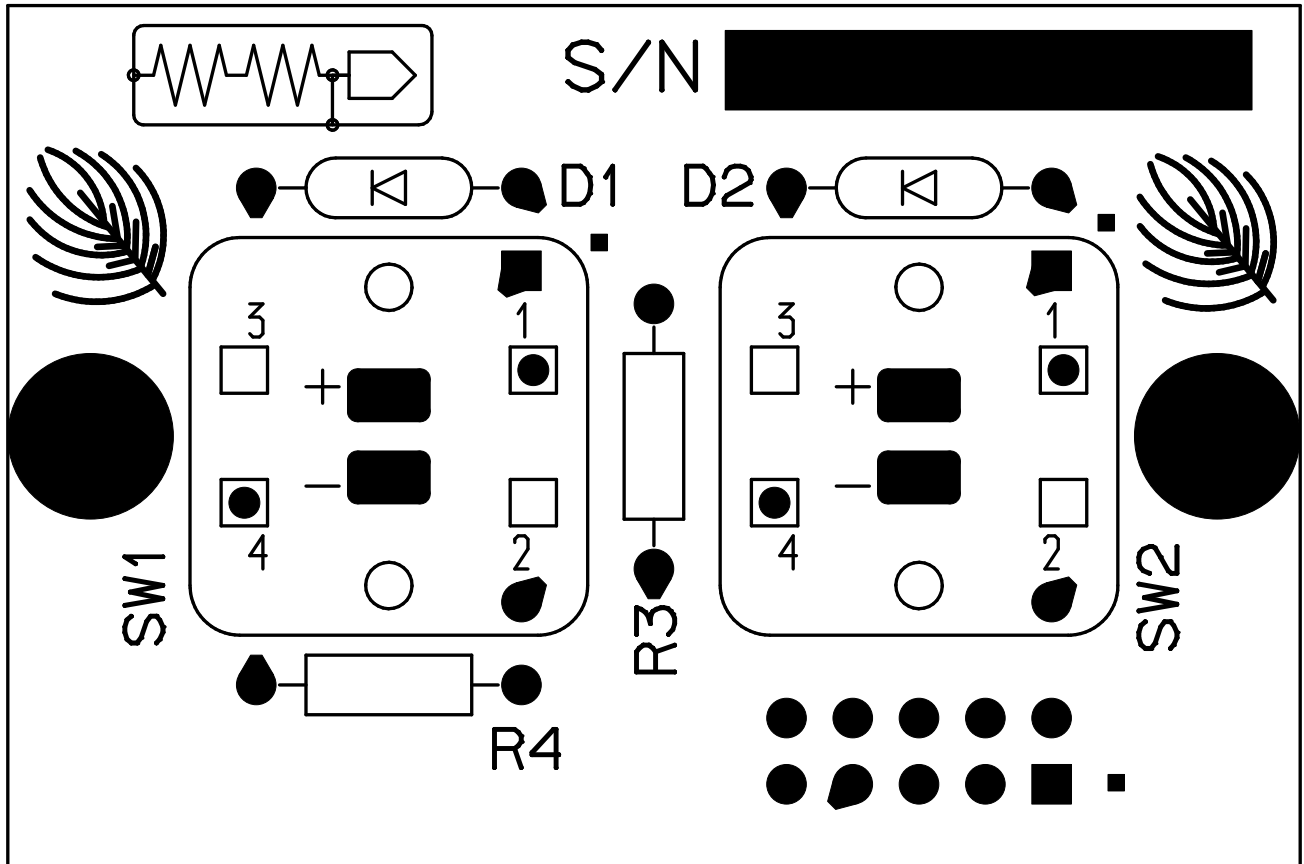

ONSW-12 Input Module On/Off Switch Card Load Sheet

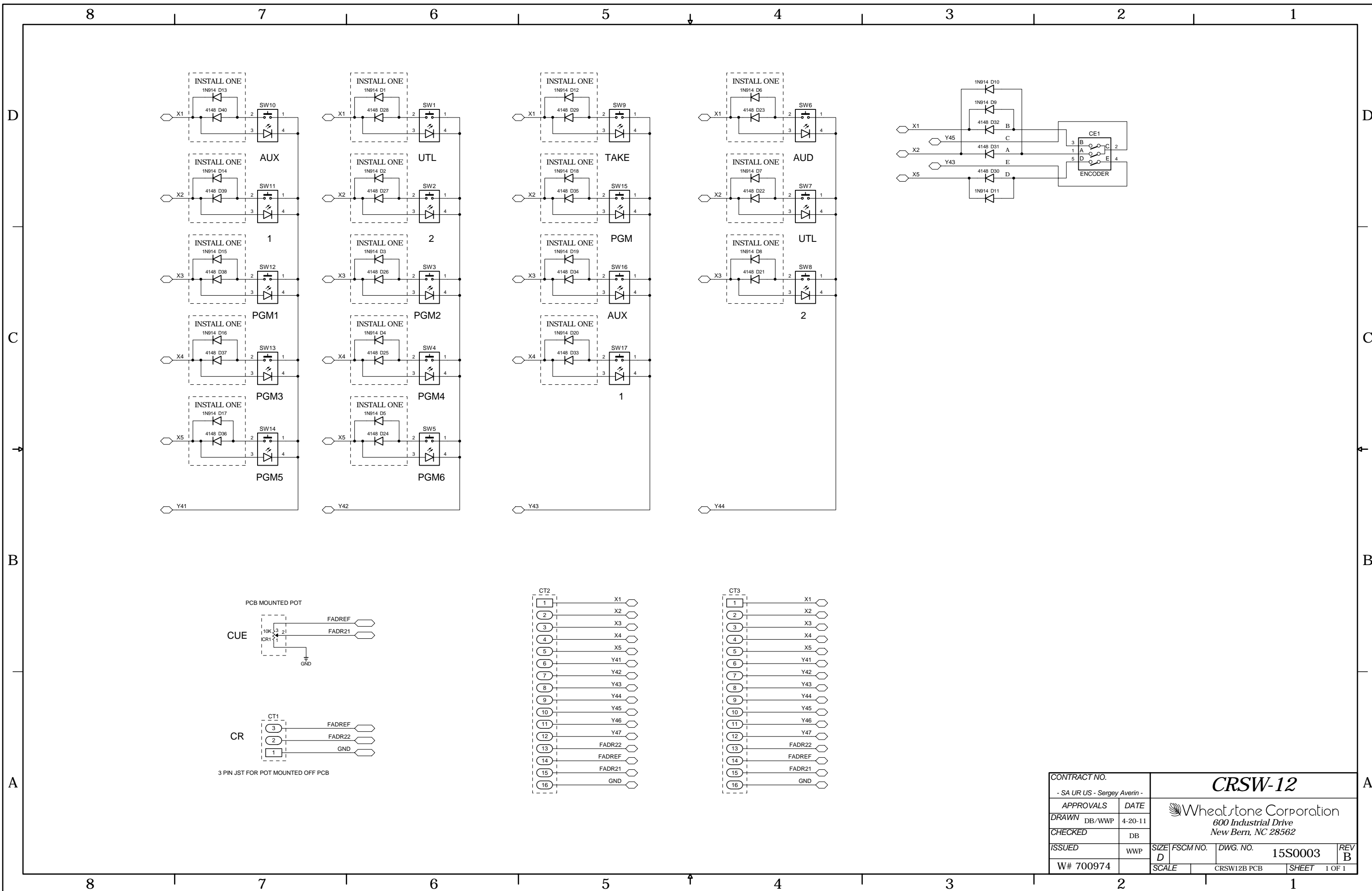

CONTRACT NO.		CRSW-12	
- SA UR US - Sergey Averin -		Wheatstone Corporation 600 Industrial Drive New Bern, NC 28562	
APPROVALS	DATE		
DRAWN DB/WWP	4-20-11		
CHECKED	DB		
ISSUED	WWP	SIZE D	FSCM NO. DWG. NO. 15S0003
W# 700974		SCALE	CRSW12B PCB SHEET 1 OF 1

CRSW-12 Control Room Module Switch Card Schematic - Sheet 1 of 1

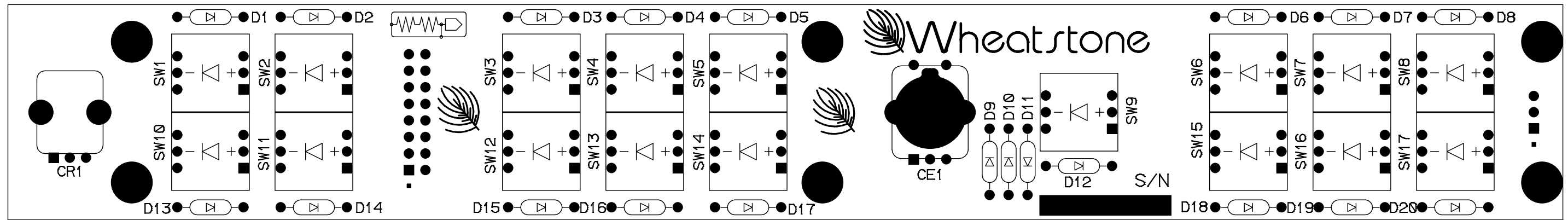

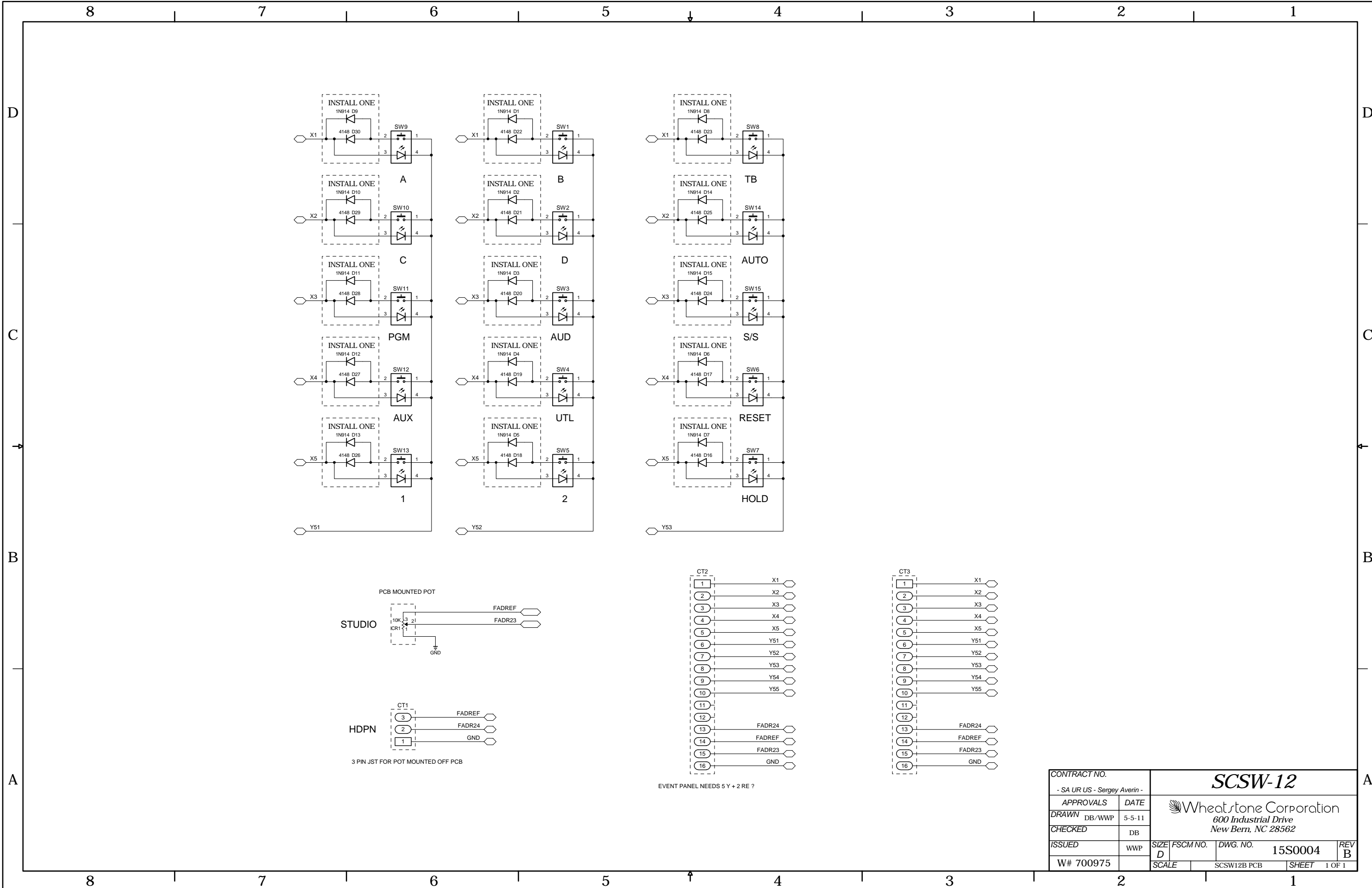

CONTRACT NO.		SCSW-12			
- SA UR US - Sergey Averin -		Wheatstone Corporation 600 Industrial Drive New Bern, NC 28562			
APPROVALS	DATE				
DRAWN DB/WWP	5-5-11				
CHECKED	DB				
ISSUED	WWP	SIZE D	FSCM NO.	DWG. NO. 15S0004	REV B
W# 700975		SCALE	SCSW12B PCB	SHEET 1 OF 1	

SCSW-12 Studio Control Module Switch Card Schematic - Sheet 1 of 1

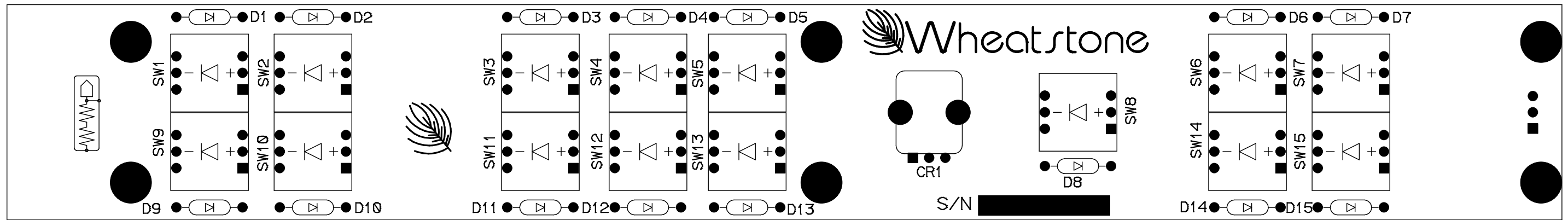

Appendix

Contents

Replacement Parts List.....	A-2
-----------------------------	-----

For the most part there are no user-replaceable parts in the IP-12/IP-16 control surface. Exceptions are those controls and components that in the course of normal use may need maintenance (i.e., faders, pots, ON/OFF switches, etc.). A complete list of available components follows. Contact Wheatstone technical support for further information.

Wheatstone Corporation (600 Industrial Drive, New Bern, North Carolina, USA 28562) may be reached by phone at 252-638-7000, fax 252-637-1285, or electronic mail “techsupport@wheatstone.com”.

REPLACEMENT PARTS - IP-12/IP-16 CONTROL SURFACE

COMPONENT	DESCRIPTION	WS P/N
IN-12 MODULE	INPUT MODULE	009000
CR-12 MODULE	CONTROL ROOM MODULE	009001
SC-12 MODULE	STUDIO CONTROL MODULE	009002
BK-IP12 FACEPLATE	BLANK FACEPLATE	009019
IPSW-12 LOADED CARD	INPUT MODULE LOADED SWITCH CARD ASSEMBLY	009021
CRSW-12 LOADED CARD	CONTROL ROOM LOADED SWITCH CARD ASSEMBLY	009025
SCSW-12 LOADED CARD	STUDIO CONTROL LOADED SWITCH CARD ASSEMBLY	009027
ONSW-12 LOADED CARD	ON/OFF SWITCH LOADED CARD ASSEMBLY	009023
HC-12 LOADED CARD	HOST CONTROL LOADED CARD ASSEMBLY	009029
POWER SUPPLY	25W TRIPLE OUTPUT DESKTOP POWER SUPPLY	980038
POWER CONNECTOR	STRAIGHT DIN RECEPTACLE	260095
FADER	MONO LINEAR TAPER FADER WITH LONGER KNOB BRACKET	540052
FADER KNOB	BLACK FADER KNOB WITH WHITE LINE	520041
POT	10K SINGLE LINEAR PC VERTICAL MOUNT 9MM POT	500126
POT	CONDUCTIVE PLASTIC SINGLE LINEAR 10K POT NO C/D, 1/8" SHAFT	500127
POT KNOB	15mm BLACK PUSH-ON KNOB FOR 6mm SHAFT	520125
POT KNOB	21mm BLACK COLLET KNOB FOR 1/8" SHAFT, NO LINE	520126
POT CAP	11mm BLACK/005 CAP W/ LINE FOR 15mm KNOB	530037
POT CAP	11mm BLACK PLAIN CAP FOR 15mm KNOB	530279
POT CAP	21MM BLACK CAP WITH WHITE LINE	530319
ON/OFF SWITCH	SINGLE POLE MOMENTARY REED KEYBOARD SWITCH	510109
NKK SWITCH	JB15 SWITCH W/BRIGHTER GREEN LED AND SILICON GASKET	510289
NKK SWITCH	JB15 SWITCH W/BRIGHTER RED LED AND SILICON GASKET	510290
NKK SWITCH	JB15 SWITCH W/BRIGHTER YELLOW LED AND SILICON GASKET	510291
NKK SWITCH CAP	WHITE SWITCH CAP	530004
ON/OFF SWITCH CAP	SOLID WHITE CAP FOR 03 STYLE SWITCH	530361
ENCODER	11mm ROTARY ENCODER WITH THREADED BUSHING, 13.5mm SHAFT LENGTH	560003

REPLACEMENT PARTS - IP-12/IP-16 CONTROL SURFACE

COMPONENT	DESCRIPTION	WS P/N
POWER CONNECTOR	8 POSITION PLUG HOUSING	<i>200122</i>
POWER CONNECTOR PIN	40 AMP RIGHT ANGLE PCB MOUNT PLUG LONG	<i>200117</i>
FLAT RIBBON CABLE	26 COND FLAT RIBBON CABLE	<i>150083</i>
PLUG RIBBON	10 PIN RIBBON PLUG	<i>230020</i>
PLUG RIBBON	16 PIN RIBBON PLUG	<i>250039</i>
PLUG	3 PIN PLUG FOR #26 AWG	<i>230028</i>
HEADER	3 PIN .098" HEADER	<i>250062</i>
HEADER	5 PIN .098" HEADER	<i>250064</i>
HEADER	16 PIN BOXED HEADER, STRAIGHT	<i>250075</i>
HEADER	10 PIN BOXED HEADER, STRAIGHT	<i>250077</i>
HEADPHONE JACK	RTS JACK	<i>260005</i>
CONNECTOR	RJ45 SINGLE UPRIGHT SHIELDED CONNECTOR	<i>260048</i>
CONNECTOR	3 POSITION EURO STYLE TERMINAL BLOCK	<i>260078</i>
ON/OFF SWITCH LED	YELLOW LED ON/OFF SWITCH	<i>600031</i>
ON/OFF SWITCH LED	3MM RED LED FOR ON/OFF SWITCH	<i>600077</i>
CLOCK DISPLAY	SINGLE DIGIT LED DISPLAY	<i>610004</i>
SOURCE DISPLAY	CUSTOM LCD ALPHA/NUMERIC DISPLAY	<i>610026</i>
SPEAKER	NOTEBOOK SPEAKER	<i>960014</i>
MANUAL	TECHNICAL MANUAL FOR IP-12 CONSOLE	<i>009099</i>