

AURABIP-3

WHEATNET-IP BLADE-3 WITH 8 VORSIS PROCESSORS



AURA8IP-3

WHEATNET-IP BLADE-3 WITH 8 VORSIS PROCESSORS

Placing a processor everywhere
you'd like one has been a costly
and impractical proposition.

Until now.

With a single Aura8-IP-3, you can
have up to eight processors to use
as you wish. Use it as a standalone
processor with analog and digital
inputs or make it a part of your
WheatNet-IP network. Either way,
the Aura8-IP-3 is a powerhouse.

Aura8IP-3

WHEATNET-IP BLADE-3 WITH 8 VORSIS PROCESSORS



Imagine your audio chain. Now imagine it on legal steroids...

The Aura8-IP-3 Audio Processing BLADE-3 brings two of Wheatstone's core technologies together (Vorsis Ultra-High Resolution Audio Processing and WheatNet-IP Intelligent Network) to provide a convenient and cost effective way to provide audio processing wherever you need – standalone or on your WheatNet-IP network.

The Aura8-IP-3 occupies a single rack space, but packs an impressive complement of eight fully independent Vorsis® multi-band stereo audio processors. Each processing chain consists of a 4-band parametric equalizer followed by a crossover and three bands of compression. The compressors each feed their own limiters, whose outputs are then fed to a broadband lookahead limiter for tight peak control. The Aura8-IP-3 has its own local I/O, with four stereo pairs of AES digital audio and four stereo pairs of analog line level audio in and out, and can function as a standalone processing engine. Because it's a BLADE-3, it can also instantly configure itself as part of a new or existing WheatNet-IP Intelligent Network, making its processing power available throughout that network.

The Aura8-IP-3 is configured and controlled over Ethernet using a laptop or desktop computer. Included with the unit is Wheatstone's acclaimed "Audio Processing GURU®" software, which allows easy setup of the processing using familiar, straightforward controls. Also available is a more sophisticated control interface called "GUI Pro," which provides access to every individual processing parameter for expert-level adjustments.

ULTRA-HIGH RESOLUTION PROCESSING

Wheatstone believes that you should have the power to shape your OWN sound – one with a completely unique sonic signature that's your sound, not the one created by a processor manufacturer. To achieve this goal Wheatstone has developed Vorsis Ultra-High Resolution Processing technology to provide completely clean, high quality 'draw you in' sound that even the best ears in the business love to hear. This proven Vorsis technology is embedded in every Wheatstone processor to create the cleanest sound, as loud as you want it.

To get there, it required taking a completely fresh approach to processing. Vorsis Dynamics Control (AGC and compression) employs multiband AGC to ensure consistent spectral balance. Its Multiband Compressor works with the AGC to provide unprecedented dynamics control.

Vorsis' Superior Stereo Enhancement is integral to the processing and creates a smear-free perception of a wider sound field in the cleanest possible way. Just stunning.

Our limiting and clipping are, bar none, the finest you'll ever use. Up to 31-bands ensure surgical precision and the ability to have the cleanest, loudest signal on the dial.

Vorsis' presets are also some of the finest in the world. You may never need to tweak them, but if you do, our Graphical User Interface, accessed by a PC, gives you an intuitive toolset that'll make you feel right at home.

We think Wheatstone's Vorsis Ultra-High Resolution Processing is the best you'll ever use. But don't take our word for it. Try it out. We CAN guarantee you'll be happy you did!

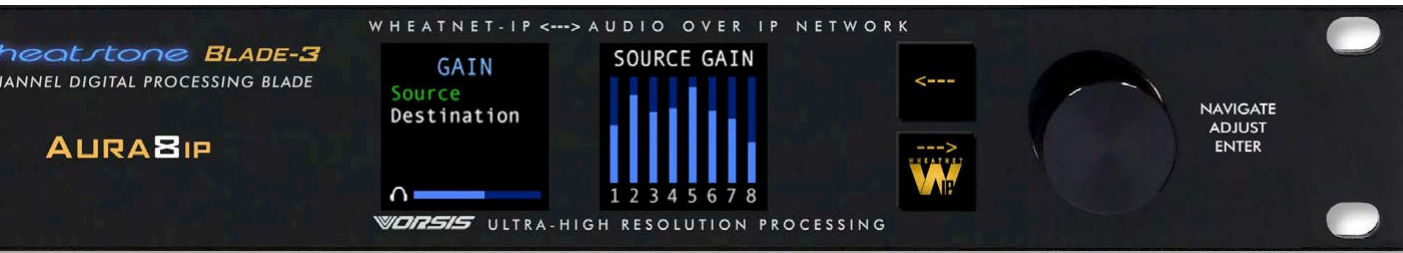

The Wheatstone Aura8-IP-3 is as easy to use as selecting presets. Yet, using the included Audio Processing Guru® software, you can easily customize your presets to get exactly the sound you are after.

Processing feeds has never been easier. The synergy in this product of two winning technologies – WheatNet-IP and Wheatstone processing – invites some extremely creative and powerful network designs. As with all BLADE-3s, a routing matrix and routing control interface are included, as well as two 8-channel stereo utility mixers which can be controlled either by WheatNet-IP Navigator software or by the Sideboard control surface, which can be used for a wide range of applications (for example, using Wheatstone’s ACI Automation Control Interface, your automation system can control the mix for satellite or local insertion switching).

It’s also got a built-in web server, so you can configure and control locally or remotely without having to run dedicated software. There’s flexible GPI logic with 12 universal logic ports, programmable as inputs or outputs and routable throughout the entire system, SNMP messaging for alerts, and silence detection on each output that can trigger alarms or make a routing change.

Because it’s a BLADE-3 with eight processors, it’s perfectly positioned to handle some unique applications involving dynamic functions that are not easily handled with conventional gear. And as with all Wheatstone products, it’s made right here in New Bern, NC, USA.

- Highest performance 24-bit A/D and D/A convertors
- AES67 compatible
- 8 complete Vorsis multiband processors, each with:
 - 4-band parametric equalizer
 - 3-way crossover
 - 3 compressors
 - 3 limiters
 - Final lookahead limiter
- Two 8-channel utility mixers
- 4 AES digital inputs on RJ-45 and “D” connectors
- 4 stereo analog inputs on RJ-45 and “D” connectors
- 4 AES digital outputs on RJ-45 and “D” connectors
- 4 stereo analog outputs on RJ-45 and “D” connectors
- Can be used standalone or as part of a WheatNet-IP Intelligent Network
- Built-in router control
- Front panel headphone jack
- Socketed output chips
- Front panel metering
- Rugged power supply
- Colorful OLED display
- Silence sensing can be applied to any output
- One Gigabit Ethernet port

using Aura8IP-3

THE APPLICATIONS ARE VIRTUALLY LIMITLESS.

What can you do with the Aura8-IP-3? Virtually anything you want! These are just a few of the ways you might use Aura8-IP-3. As a standalone processor, you get eight stereo channels of jaw-dropping Voris ultra high resolution processing power for under \$500 per channel. That alone is worth the price of admission. But...

Low Latency Talent Headphone Processing

Often, the key to talent turning in their best performances is what they hear in their headphones. Give them a sound that drives them to brilliance with Aura8-IP-3.



Remote Feed Conditioning



The great and hard thing about radio is that you can tie the world together on your broadcast. That means you can have audio flying in from all over. Aura8-IP-3 is exactly what you need for all of it, at a price that will make you very happy!



Mic Processing

Every microphone does a better job when it's processed not only for the voice that's speaking into it, but for the path it's taking on the way to someone's ears. Aura8-IP-3 does a superb job processing microphone audio.



Satellite Uplink Peak and Spectral Control

The key here is keeping signals under control. Aura8-IP-3 is perfect for the job, keeping an eye (or ear) on the peaks as well as ensuring the spectral range stays consistent.



STL Pre-Processing and Protection-Processing



There are a lot of dedicated STL systems out there. Or, if you have a WheatNet-IP, it's the perfect solution. No matter HOW you handle STL, let Aura8-IP-3 handle processing to ensure the audio is optimized for it.

Multiple HD Feeds

HD Radio gives you the option of broadcasting multiple audio streams of varying quality. Make the most of each by giving them processing that will make them stand out.



...when you take advantage of Aura8-IP-3 being a BLADE-3 with its built-in utility mixers, web server, full logic, SNMP messaging and silence detection, and use all that with its 8-channels of processing, its power is really unleashed. How many ways can YOU think of to use the Aura8-IP-3?

Talkshow Call-Ins

Processing can make a huge difference in the on-air quality of call-ins on your talk shows. Aura8-IP-3 is up to the task.



Codec Pre-Processing



Audio from codecs is subject to environmental conditions - at the source and through the connection. Processing with Aura8-IP-3 can clean it up nicely.

WHEATSTONE BLADE-3 CHANNEL DIGITAL PROCESSING BLADE

AURA8IP

WHEATNET-IP <---> AUDIO OVER IP NETWORK

GAIN Source Destination

SOURCE GAIN

1 2 3 4 5 6 7 8

ORISIS ULTRA-HIGH RESOLUTION PROCESSING

NAVIGATE ADJUST ENTER

IFB Conditioning

Clear communications between director, engineering and talent is key to presenting successful sports and multiple-report shows. Aura8-IP-3 is perfect for cleaning up IFB.



Web Streams

Whether you are streaming now or getting ready to, there's no better investment you can make in your station than to ensure those streams sound great. That's exactly what Aura8-IP-3 does.



Sweetening Incoming Commercials and Newsroom Feeds

Keeping your revenue sources sounding compelling can really help with audience perception and acceptance. Aura8-IP-3 is a cost-effective solution for ensuring your entire audio stream sounds SWEET!



Automation Streams

Wheatstone enjoys technology partnerships with the leaders in broadcast today. Use the AGC in Aura8-IP-3 to keep your automation streams clean and under control.

controlling Aura8IP-3

ONE VERY POWERFUL WINDOW LETS YOU DIAL IN ANY SOUND YOU WANT

Aura8-IP-3 GURU Software GUI

Basic setup is via Aura8-IP-3 AUDIO PROCESSING GURU® Software, which is included.

Install it on a Windows® PC, and connect to the Aura8-IP-3 directly, over a network, or over the Internet.

With it, you get basic control over day-to-day parameters as well as the ability to tweak the factory presets in the most musical way you can imagine. We've grouped control over literally hundreds of individual processing functions in an intelligent configuration that changes groups within the presets collectively. What you get is immediate aural gratification.

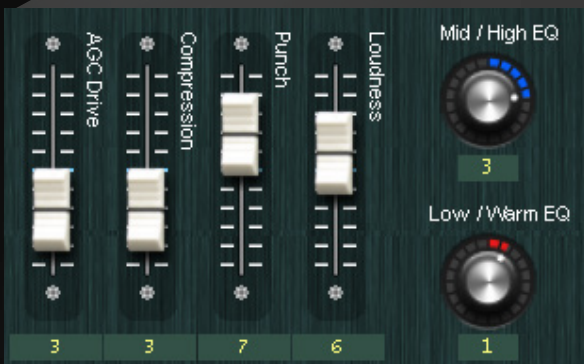

For The Audio Processing Tweaker

Audio Processing Guru® Software gives you six easy to understand controls to customize any preset. Each control changes multiple parameters behind the scenes to ensure intelligent adjustments to your sound. It's like having your own audio guru with you when you tweak!

For The Individual Processing Guru

Most stations find they can get a great sound just by using one of the many pre-loaded factory presets. But for those wanting a more hands-on approach, Wheatstone offers free GUI PRO software—an incredibly extensive palette of controls, backed by a comprehensive instruction manual to guide you step-by-step. Unlike most other processors, with Vorsis GUI PRO no control is hidden; they are all there for you to tweak.

inside Aura8IP-3

THE GUTS. THE GLORY.

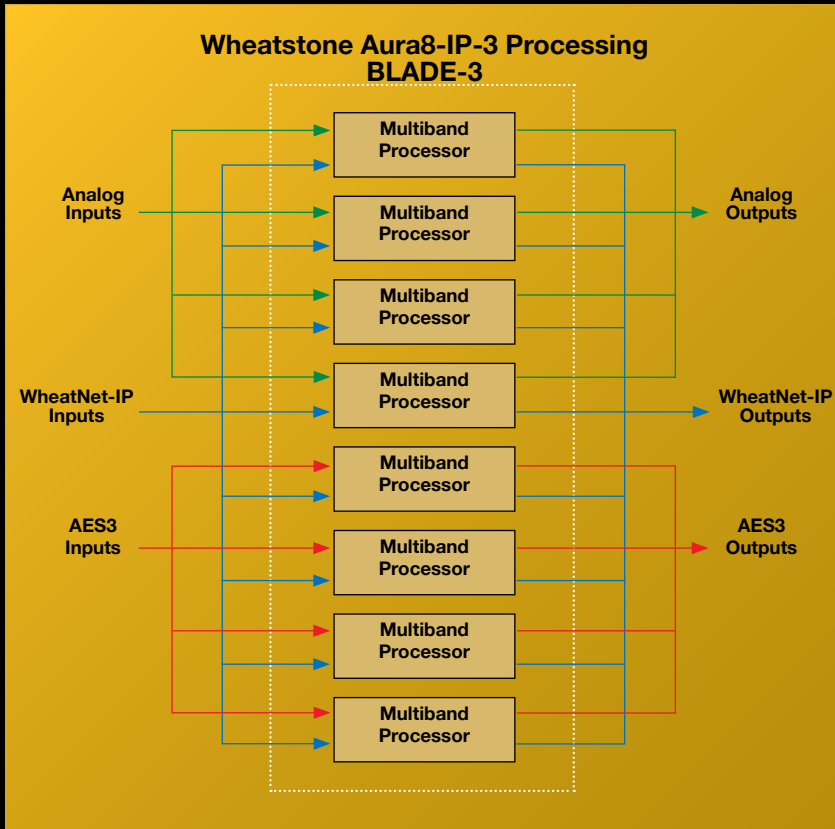

Aura8-IP-3 Audio Processing Overview

The block diagrams on the left show the internal structure of the Aura8-IP-3 Processing BLADE-3.

The top graphic shows how four of the eight processors are equipped with analog I/O and four are equipped with digital I/O when run in stand alone mode, and all eight are equipped with Wheatnet-IP audio inputs and outputs when run in networked mode.

The bottom graphic shows the 3-Band, 2-Band, and Broadband processing signal paths.

Signal flow in Broadband, 2-Band and 3-Band modes

Note: EQ may be placed pre OR post AGC/Compressor

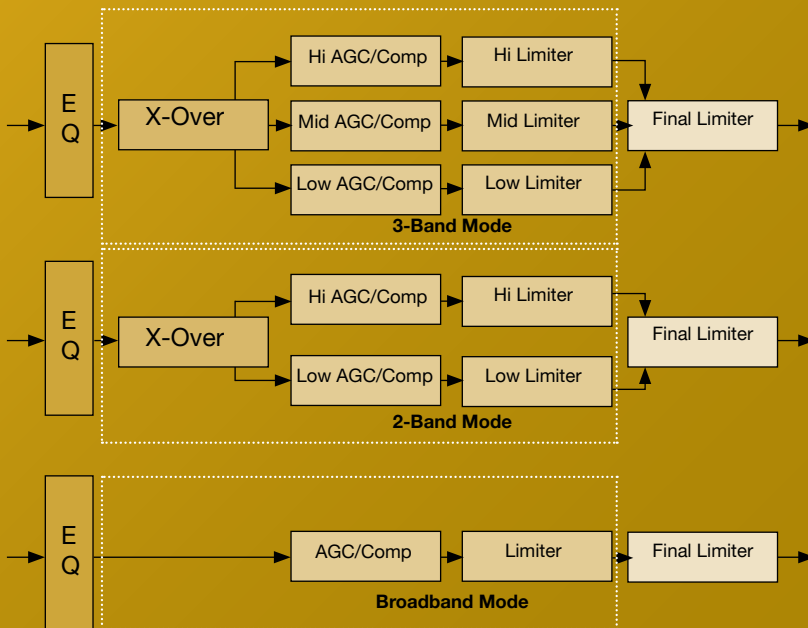

Wheatstone Processing Buzz

Real Comments From Real Users About Wheatstone's Ultra-High Resolution Audio Processing

"I am giving the Vorsis development team a BIG thumbs up as this product stands out as a very SUPERIOR audio processor design."

"This processor is amazing!"

"I have the HD output feeding our web stream encoder, and two national program hosts at remote locations in the US have told us 'your audio stream sounds incredible!'"

"I can say that the Vorsis processor does NOT sound like the "O"ther guys! It sounds far better and has a very unique 'signature.' I really, really like how this processor sounds! Every other station in the market sounds like crunched up FM radio while our station is loud now and yet it still has "life" with CD quality dynamics and punch."

"I've listened to the station since the first few days after the format flip (which was a month ago yesterday), and the one thing I notice most is that the new Vorsis processor's audio quality is always terrific, regardless of the source material."

"If the Vorsis that I heard while you were testing processors last night is your final air chain (it was) it might just be the cleanest and best sounding FM I've heard since...well, forever. Great work!"

"Your Sweet Spot Technology AGC has the most invisible gain correction that I have EVER heard in ANY on-air processor. Listeners have been calling to compliment us on the improvement in our on-air sound."

"We've used your product close to a year now and it's just out of this world. When we put the Vorsis box online our audience noticed the difference instantly and started calling asking questions like 'What's going on? What did you all do? Your sound is clear, crisp, and bright and the audio sound level is great now!!!"

"The music sounds great, and this box can be tweaked to anyone's preference. There is a lot to discover in this machine.....but our single biggest achievement has been achieving the clearest, cleanest 'voice' I have ever heard come from an FM processor."

"I am extremely impressed with the unit's capabilities and how well it performs with our NPR talk/Classical format."

"What an amazing difference in sound quality!!! This is a brand new FM station and comparing it to the other new station in town using the Other brand of processor our client is louder, cleaner, and even legal. Wheatstone definitely has a winner here with Vorsis."

"Thanks for a great sounding box that makes us sound bigger than the so called big stations!"

"This is a great sound and we are so, so pleased with our new Vorsis on-air processor. You just threw down the gauntlet to the processing industry with this new unit! Nobody can match a sound this loud, this clean, and this unique! Now everybody gets to chase after us for a while. Thanks Vorsis!!"

"Our signal used to virtually disappear in downtown New York when we went on night pattern because of the extremely high level of man-made noise. Now when we're on night pattern our coverage in downtown is actually better than when we are on day pattern, the other brand of audio processor and a 10X higher powered transmitter! We're buying a second one to put on our daytime transmitter!"

"You have to be kidding! I have NEVER heard FM audio sound this good, this detailed, this smooth, this clean, and this loud (how did you do it??). Very nice work!"

"Love the box!!! Overall the sound of the station is vastly improved. It's loud, wide and clear."

"I guess the only word for Vorsis is 'WOW.' It's got some great bottom end, and it's more transparent than any processor I've heard."

"The AGC/Compressor/SST combination is simply amazing. We play classical CDs. Older classical CDs were mastered at a much lower level than current ones. Announcers don't compensate and never will. Your processor is able deal with what amounts to probably 40-45dB (or more) average level variations and hold them perfectly in the sweet spot with virtually no squashing, pumping, sucking, or other usually audible artifacts of such wide range level control. In short it does its job perfectly every time."

"I love classic rock and it's the program format on the station that I own. No other processor that I've tried (and I think I've tried them all!) sounds as good on this format. We're nice and loud and still cleaner than the other stations in the market. We were surprised to hear the intentional dynamics of songs actually get on the air - other processors just flatten them out or turn them into a sea of mush. For the first time ever we're also hearing subtle nuances in songs that we used to think we knew every single note of. What an amazing air sound! No...What an amazing processor!!"

"This box sounds much better than any other processor I have ever tried. Ever!"

"Your equalizers are actually useful and, unlike other processors, do not grunge-up the sound merely by enabling them."

"The SST algorithm is the least audible of ANY processor I have ever had experience with. I'm not sure how you did it or exactly how it works but its automatic "leveling" is excellent - no pre-processing whatsoever is necessary with SST."

"The high end of this processor is very open sounding - there is no fake "sparkle" with the HF EQ either. Perfectly clean and natural sound. And did I mention LOUD?"

"Finally! A processor that deals effectively and transparently with overly-sibilant announcers and audio levels that usually go all over the place! (I especially love the tweakable multiband thresholds!)"

"Why haven't the other audio processor companies been able to make an AM box that sounds this good? I can't think of a positive superlative that is big enough to describe how pleased I am with our AM sound now. Our coverage seems to have increased by quite a bit too!!"

"Our multipath is Gone! GONE! As an engineer I have difficulty believing a processor can make this much difference in apparent coverage area but the listening is the proof. We've had several listeners call and comment that their reception has greatly improved and even I've noticed vast improvements when driving through what were previously horribly multipath prone areas. I'm not sure why, but it sure does work!!"

"This box has great metering and excellent analytical tools - you get good visual indication of everything that is happening inside."

"The unit's stability has been flawless, not even a tiny glitch. We have it set up to time-sync and it works great. The scheduler-based (and SILENT!!) preset switching is perfect! Unit sounds very accurate sonically and is very easy to set-up."

"We are now VERY unique in our audio. Compared to other stations in the market, we are as loud yet maintain legal modulation (at least 4 stations in our market run with 130%+ modulation). We're not "squashed" sounding at all and if you compare us with the other stations (all formats) we're clearly a dynamic and clean stand-out signal on the dial now."

WHEATSTONE AURA8-IP-3 SPECIFICATIONS



Specs For Aura8-IP-3:

Inputs	4 Stereo Analog inputs on "D" connectors and RJ-45. 4 AES Digital inputs on "D" connectors and RJ-45.
Outputs	4 Stereo Analog outputs on "D" connectors and RJ-45. 4 AES Digital outputs on "D" connectors and RJ-45.
Logic	12 Universal Logic ports
Processing	8 Vorsis embedded multi-band processing chains, each with 4-band parametric equalizer, 3-way crossover, 3 compressors, three limiters, broadband lookahead limiter

PRESETS

Non-volatile memory	Storage for 80 presets
Factory	More than 25 pre-installed and write-protected New factory presets can be downloaded from the Wheatstone Processing web site and installed via the Aura8-IP-3 Software

Common Specs to all BLADE-3s:

LOGIC I/O

Connectors	RJ-45 (2), 12 channels
Voltage	+5VDC to GND +5VDC and GND provided
Current	100mA max source/sink

ETHERNET

Connectors	RJ-45
Cable	CAT5E or CAT6
Audio transport	Gigabit Ethernet 1000BASE-T, used for all BLADE-3-to-BLADE-3 audio traffic
Utility interface	100BASE-TX for future use

SYSTEM

Sample rate	44.1 or 48kHz, user-selectable in software
Sync	Internal or external External sync input
Reference level	0dBFS=+4dBu (+4dBu=1.23VRMS)
Latency	0.5mS, BLADE-3 to switch to BLADE-3

PHYSICAL

Dimensions	1RU 19"/48.3cm wide 1-3/4"/4.5cm high 13-1/4"/33.7cm deep 15-1/4"/38.7cm deep with connectors
Shipping weight	14lbs/6.4kg
Power consumption	23VA, 12W

Specifications and features subject to change without notice.

Designed and built by
Wheatstone Corporation
600 Industrial Drive | New Bern NC 28562-5440 USA
phone 1.252.638-7000 | fax 1.252.635-4857
wheatstone.com | sales@wheatstone.com

 **Wheatstone**
BROADCAST AUDIO PERFECTIONISTS®